



**SUZUKI**  
**MARINE**

Parts Book  
DT20 86~88

## PREFACE

When it becomes necessary to replace parts on SUZUKI OUTBOARD MOTORS, always use SUZUKI GENUINE PARTS which have passed a strict inspection which guarantees quality and performance.

This parts catalogue covers the list of all service parts for SUZUKI DT20 VG, VH, VJ.

### INSTRUCTIONS FOR QUOTING THE CATALOGUE

#### 1. DIMENSIONS

Dimensions of the parts in this catalogue are indicated in unit millimeters.

#### 2. ABBREVIATIONS

Abbreviations used in this catalogue are as follows:

AR	: As required	NT	: Number of teeth
ASSY	: Assembly	OPT	: Optional
E.No.	: Engine number	OS	: Over size
F.No.	: Frame number	STD	: Standard
d	: Diameter of material	T	: Thickness
ID	: Inside diameter	US	: Under size
OD	: Outside diameter	W	: Width
L	: Length	S,L,UL,LL	: Transom type
LH	: Left hand side		
RH	: Right hand side		
~123456	: Up to F.No.02003-123456		
123456~	: From F.No.02003-123456		
12 x 34 x 5.6	.....Figures in the description column show the dimensions of parts.		
ID	OD	T(or W,L)	

#### 3. INNER PARTS OF ASSEMBLY

Parts number that have a period (.) mark in front of the part description on a text page are separately serviced parts of the assembly.

#### 4. MODIFICATION NOTICE

A parts bulletin will be sent to you on all occasions when changes in parts occur, including interchangeable modifications between new parts and old ones.

#### 5. NOTE

- 5-1. There are some different parts from those of production models among spare parts for the administrative reasons and common use of them with other models.
- 5-2. In respect of rubber hoses and vinyl tubes, please be sure to use them by cutting off according to the length mentioned on parts catalogue or what is actually required on the vehicle.
- 5-3. Note that the drawings on the illustration page are for ready reference of spare parts number, not to be used as an assembly manual. When assembling, use "SUZUKI SERVICE MANUAL".

#### 6. ENGINE NUMBER

DT20 VG : 02003-602983-604547  
DT20 VH : 02003-704548-705873  
DT20 VJ : 02003-805874~

#### 7. COLOR

: Color No.	:	Color description	:
: 02M	:	Arctic Silver	:
: 01T	:	Francois White-2	:

FIG.1

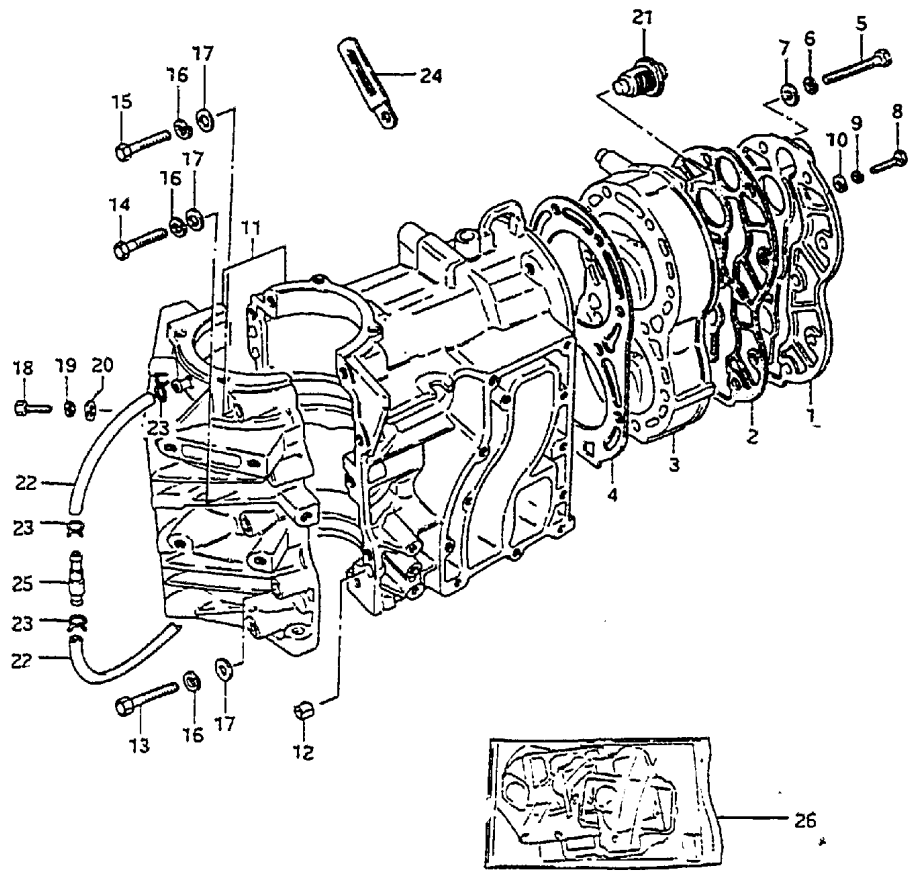

FIG.1 ( B- 2) CYLINDER

REF.NO.	PART NO.	DESCRIPTION	Q'TY	REMARKS
1	11161-96302-02M	COVER, cylinder head	1	
2	11162-96302	GASKET	1	
3-1	11111-96320-02M	CYLINDER HEAD	1	-02003-604530
3-2	11111-96321-02M	CYLINDER HEAD	1	02003-604531-
4	11141-96311	GASKET	1	
5	01107-08658	BOLT	10	
6	08321-11088	LOCK WASHER	10	
7	08322-11088	WASHER	10	
8	01107-06252	BOLT	2	
9	08321-21062	LOCK WASHER	2	
10	08322-21062	WASHER	2	
11	11301-96313-02M	CYLINDER ASSY	1	
12	04211-09109	.PIN	2	
13	01107-08552	.BOLT	4	
14	01107-08452	.BOLT	2	
15	01107-08602	.BOLT	2	
16	08321-21082	.LOCK WASHER	8	
17	08322-11082	.WASHER	8	
18	01107-06252	.BOLT	4	
19	08321-21062	.LOCK WASHER	4	
20	08322-21062	.WASHER	4	
21	17670-93962	THERMOSTAT (50°C)	1	
22	09343-03051	HOSE (3.1x6.8x330)	2	L:330+180
23	09401-06403	CLIP	4	
24	09404-06204	CLAMP (L:80)	2	
25	16710-96300	CHECK VALVE	1	
26	11400-96850	GASKET SET	1	OPT

EWB

FIG.2

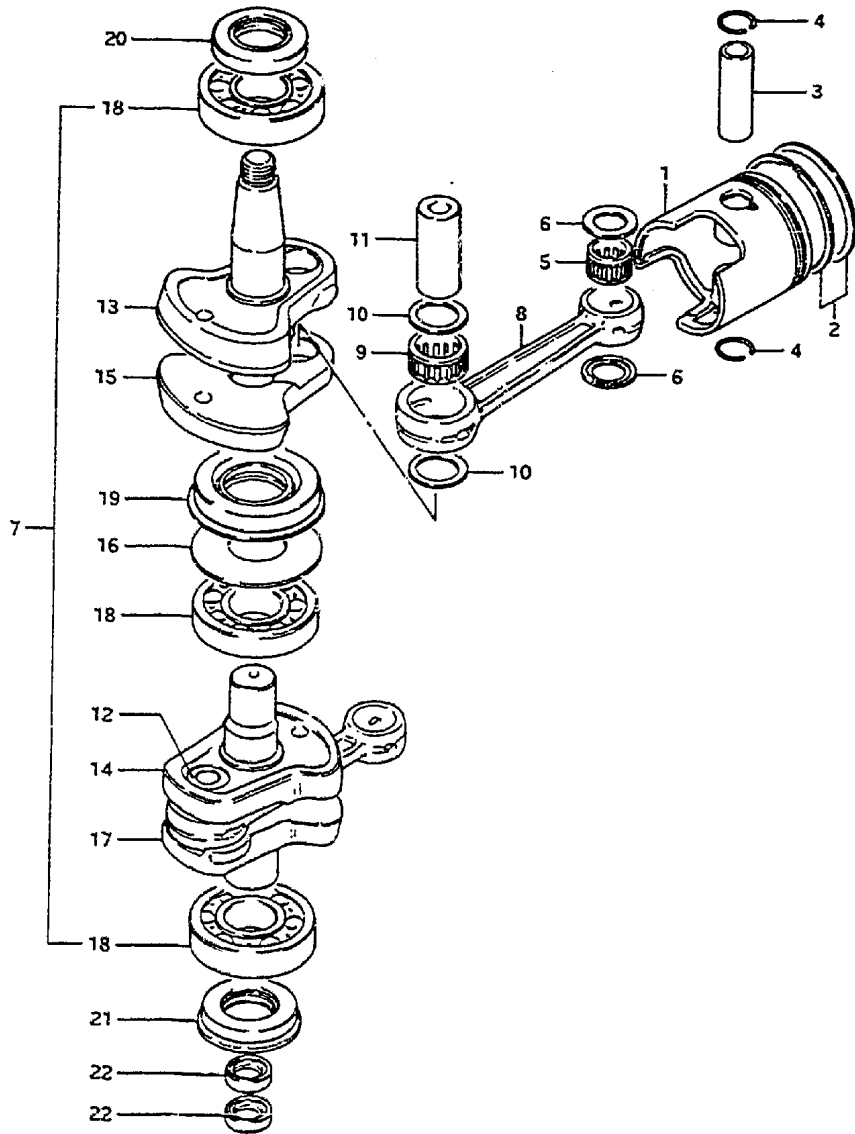

FIG.2 ( B- 3) CRANKSHAFT

REF.NO.	PART NO.	DESCRIPTION	Q'TY	REMARKS
1-1	12110-96311	PISTON	2	
1-2	12110-96311-025	PISTON, OS:0.25	2	OPT
1-3	12110-96311-050	PISTON, OS:0.50	2	OPT
2-1	12140-96310	RING SET, piston	2	
2-2	12140-96310-025	RING SET, piston, OS:0.25	2	OPT
2-3	12140-96310-050	RING SET, piston, OS:0.50	2	OPT
3	12151-92501	PIN, piston	2	
4	09381-18002	SNAP RING	4	
5	09263-18016	BEARING (18x23x22)	2	
6	09169-18001	WASHER	4	
7-1	12200-96306	CRANKSHAFT ASSY	1	-705030
7-2	12200-96307	CRANKSHAFT ASSY	1	705031-
8	12161-96300	.ROD, connecting	2	
9	09263-24018	.BEARING (24x32x20)	2	+09263-24016
10	09181-24001	.WASHER (24x31.5x1)	4	
11	12211-96311	.PIN, crank upper	1	
12	12211-96301	.PIN, crank lower	1	
13-1	12221-96304	.CRANKSHAFT, upper	1	model VG/VH
13-2	12221-96305	.CRANKSHAFT, upper	1	model VJ
14-1	12232-96303	.WHEEL, middle under	1	model VG/VH
14-2	12232-96304	.WHEEL, middle under	1	model VJ
15	12231-96302	.WHEEL, middle upper	1	
16	09160-50002	.WASHER (50x77x1)	1	
17-1	12240-96305	.CRANKSHAFT, under	1	-705030
17-2	12240-96310	.CRANKSHAFT, under	1	705031-
18	09262-30055	.BEARING (30x72x19)	3	
19	09289-38013	.OIL SEAL (37.8x77x12)	1	
20	09283-30011	OIL SEAL (30x55x10)	1	
21	09283-30042	OIL SEAL (28.5x59x10)	1	
22	09282-15004	OIL SEAL (14.7x25x7)	2	

FIG.3

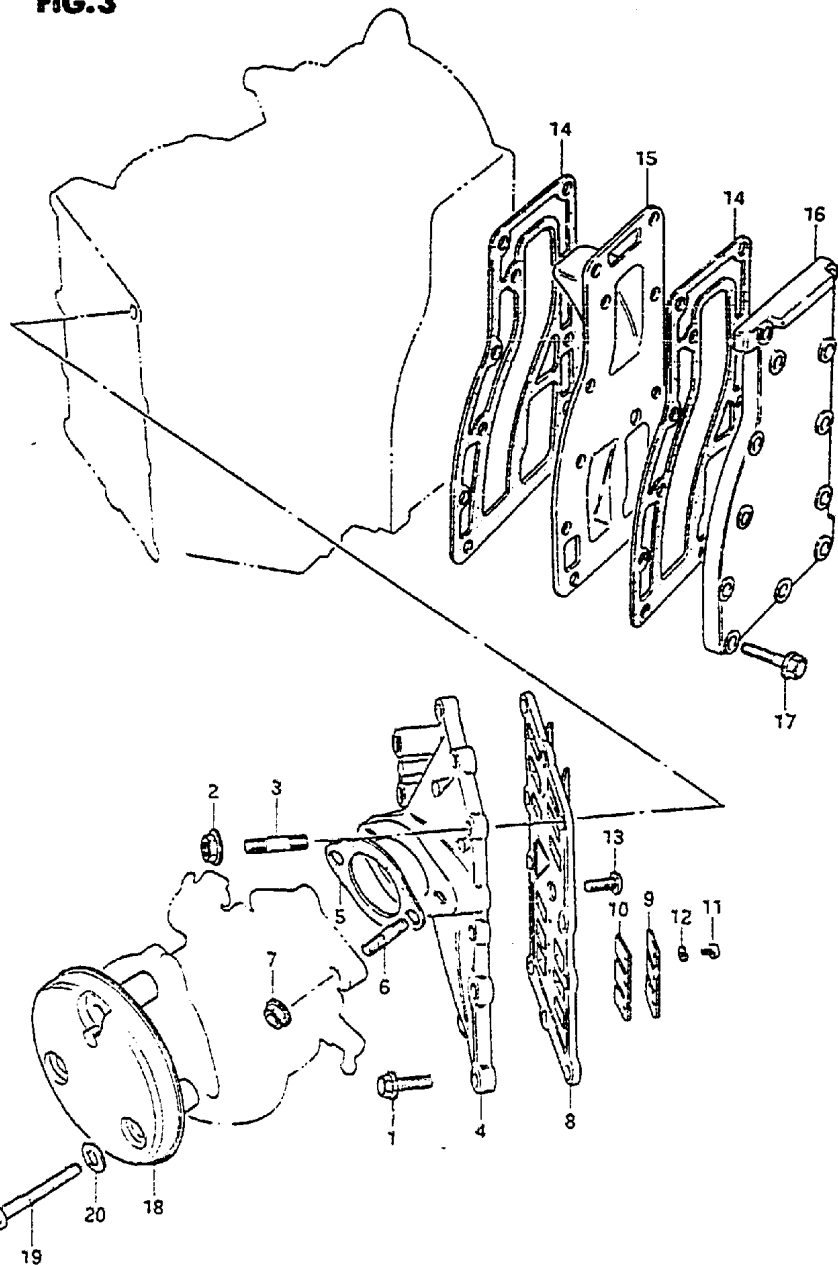

FIG.3 ( B-4) INLET CASE - EXHAUST COVER

REF.NO.	PART NO.	DESCRIPTION	Q'TY	REMARKS
1	01517-06252	BOLT	8	
2	08316-16062	NUT	2	
3	01421-06202	STUD BOLT	2	
4	12481-96301-02M	CASE, inlet	1	
5	13125-93000	GASKET, carburetor	1	
6	01411-08202	STUD BOLT	2	
7	08316-16082	NUT	2	
8	13150-96300	REED VALVE ASSY	1	
9	13152-96300	.STOPPER, reed valve	4	
10	13153-96300	.VALVE, reed	4	
11	02112-03068	.SCREW	12	
12	08321-21038	.LOCK WASHER	12	
13	02122-06167	SCREW	1	
14	14151-96300	GASKET, exhaust cover	2	
15	14131-96301	PLATE, exhaust	1	
16-1	14141-96300-02M	COVER, exhaust	1	-603526
16-2	14141-96301-02M	COVER, exhaust	1	603527-
17	01517-06252	BOLT	12	
18	13811-96300	CASE, silencer	1	
19	02112-06402	SCREW	3	
20	08322-21062	WASHER	3	

FIG.4

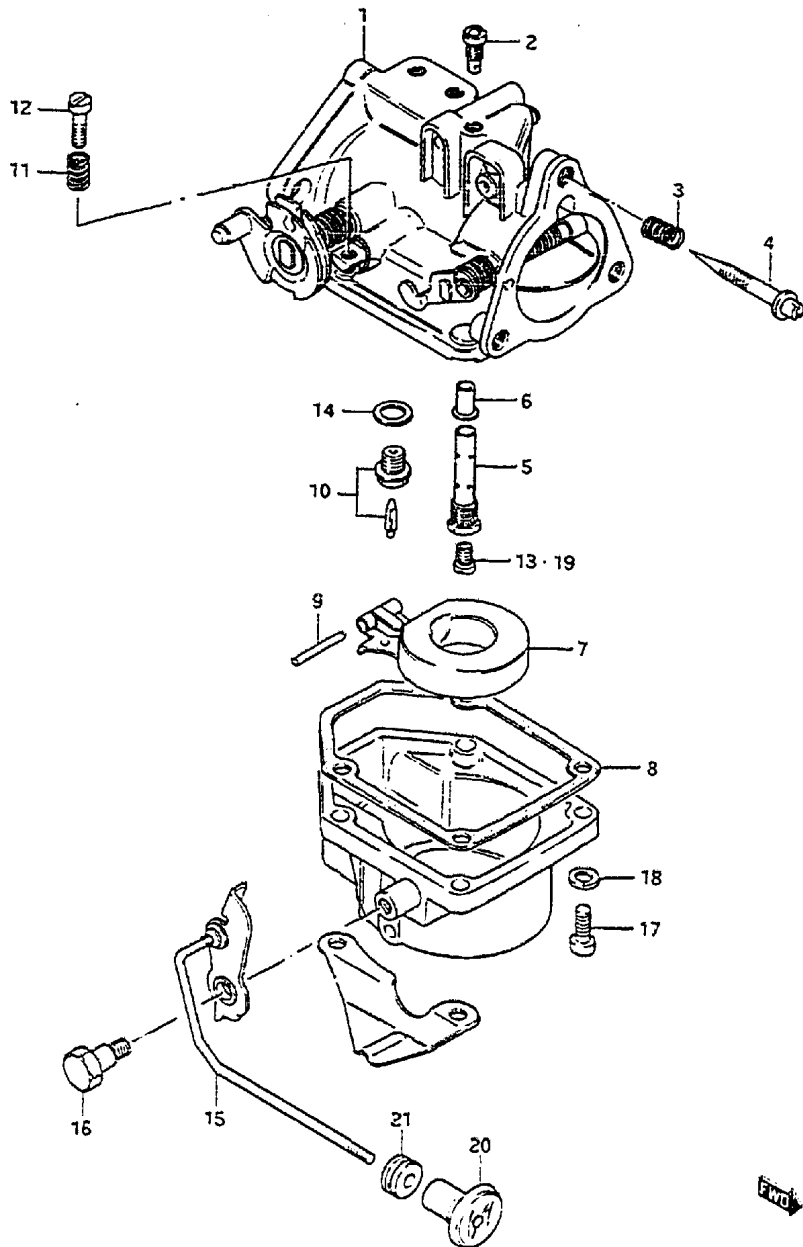
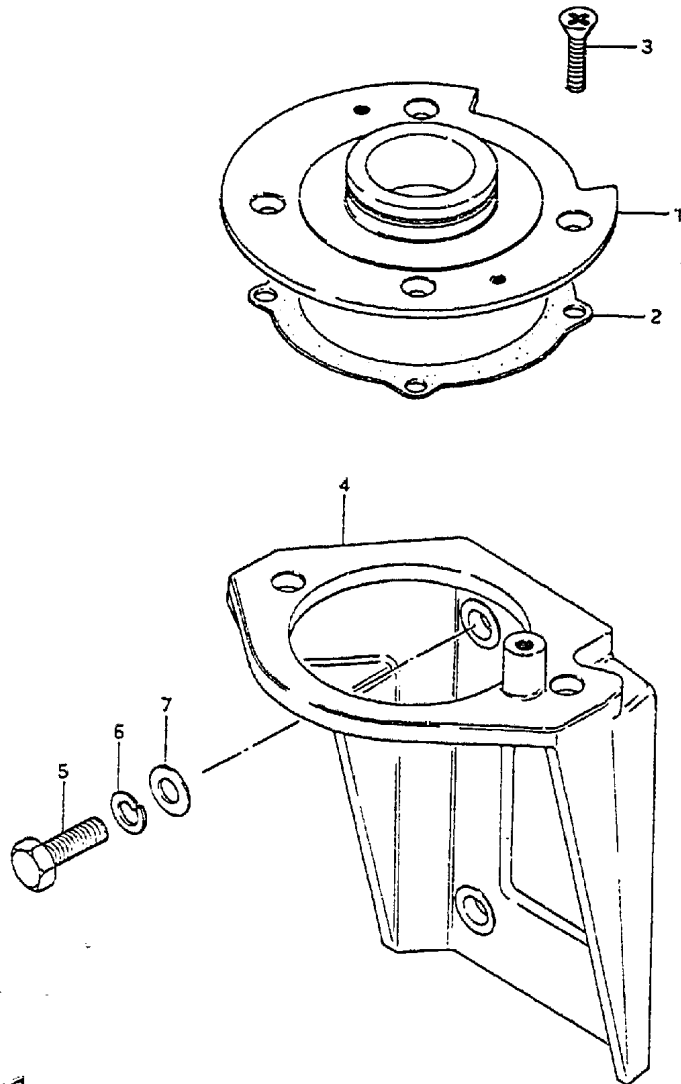

FIG.4 ( B-5) CARBURETOR

REF.NO.	PART NO.	DESCRIPTION	Q'TY	REMARKS
1	13200-96372	CARBURETOR ASSY	1	
2	09492-67002	.JET, air (67.5)	1	
3	13271-93311	.SPRING, air screw	1	
4	13269-93311	.SCREW, pilot air	1	
5	13236-94400	.NOZZLE	1	
6	13237-94400	.NOZZLE	1	
7	13250-93012	.FLOAT	1	
8	13251-93310	.GASKET, float chamber	1	
9	13254-93010	.PIN, float	1	
10	13370-28110	.VALVE ASSY, needle	1	
11	13268-96110	.SPRING, throttle stop	1	
12	13534-96300	.SCREW, throttle stop	1	
13	09491-24012	.JET, main (120)	1	
14	13392-58600	.GASKET, valve seat	1	
15	13681-96300	.LEVER, choke	1	
16	13682-96300	.BOLT	1	
17	02112-05208	.SCREW	4	
18	08321-21057	.LOCK WASHER	4	
19-1	09491-26009	JET, main (130)	1	OPT
19-2	09491-25002	JET, main (125)	1	OPT
19-3	09491-23012	JET, main (115)	1	OPT
20	13631-93500	KNOB, starter	1	
21	09305-04005	BUSH	1	

FWD

FIG.5



5

FIG.5 ( B- 6) UPPER OIL SEAL HOUSING

REF.NO.	PART NO.	DESCRIPTION	Q'TY	REMARKS
1	11411-96301	HOUSING, upper oil seal	1	
2	11413-96300	GASKET	1	
3	02122-06208	SCREW	4	
4	31911-96302-02M	BRACKET, starter	1	ELECTRIC STARTER
5	01107-08252	BOLT	4	ELECTRIC STARTER
6	08321-21082	LOCK WASHER	4	ELECTRIC STARTER
7	08322-21082	WASHER	4	ELECTRIC STARTER

FIG.6 ( B-7) FUEL PUMP

Q'TY

REF.NO.	PART NO.	DESCRIPTION	Q'TY	REMARKS
1	15100-94301	PUMP ASSY, fuel	1	
2	15170-94311	.DIAPHRAGM SET	1	
3	15183-94301	.SCREW	2	
4	15186-94300	.NUT	2	
5	15851-94300	.SCREW	3	
6	01107-06402	BOLT	2	
7	08321-21062	LOCK WASHER	2	
8	15321-99700	GASKET	1	
9	09343-05277	HOSE (FILTER - PUMP)	1	L:540+195
10	09343-05277	HOSE (PUMP - CARBURETOR)	1	L:540+195
11	09401-08410	CLIP	4	
12	15331-94300	CLIP	2	
13	15410-93400	FILTER, fuel	1	
14	15415-93400	.O RING	1	
15	15412-93400	.STRAINER	1	
16	15413-93400	.CUP	1	
17	15416-93400	.PACKING	1	
18	08322-21082	WASHER	1	
19	08310-22082	NUT	1	
20	09343-05277	HOSE (CONNECTOR - FILTER)	1	L:540+320
21	09404-06204	CLAMP (L:80)	1	

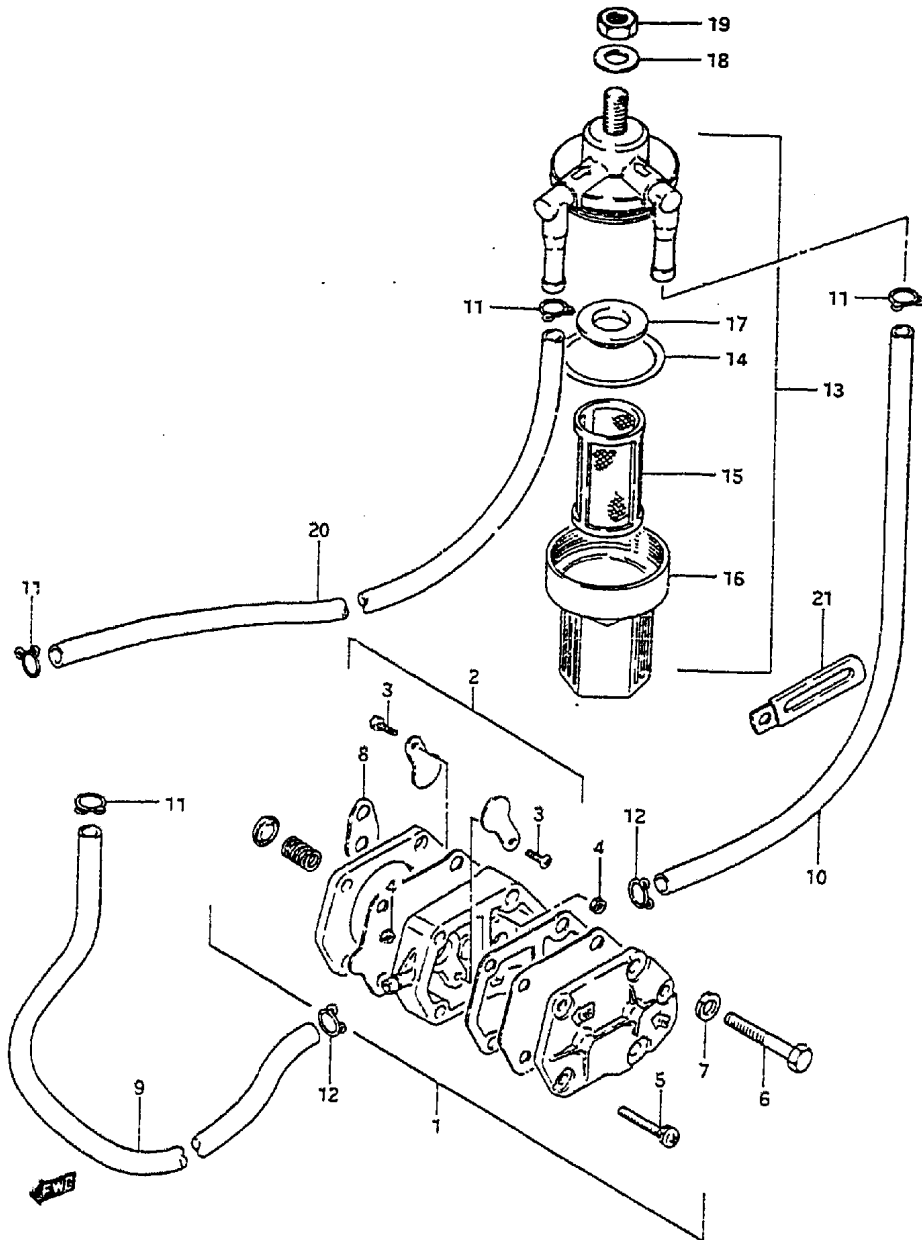



FIG.7

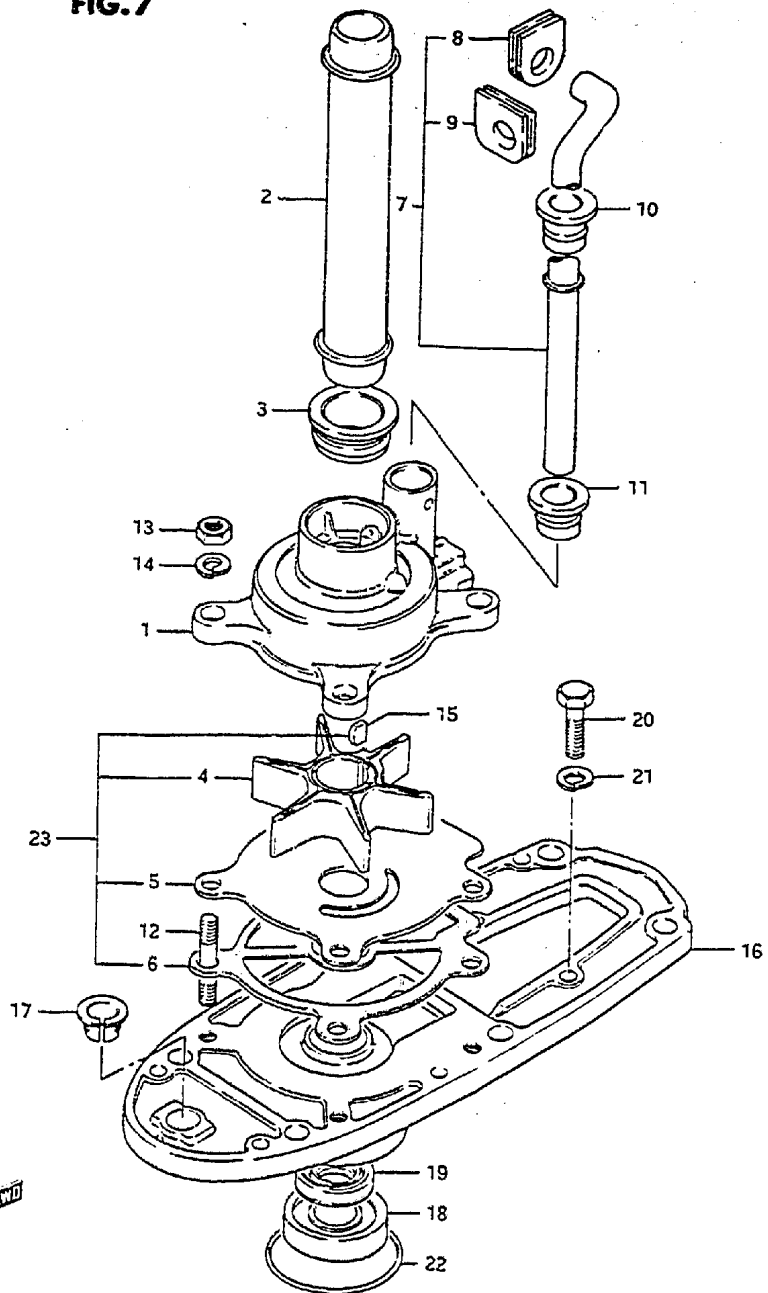
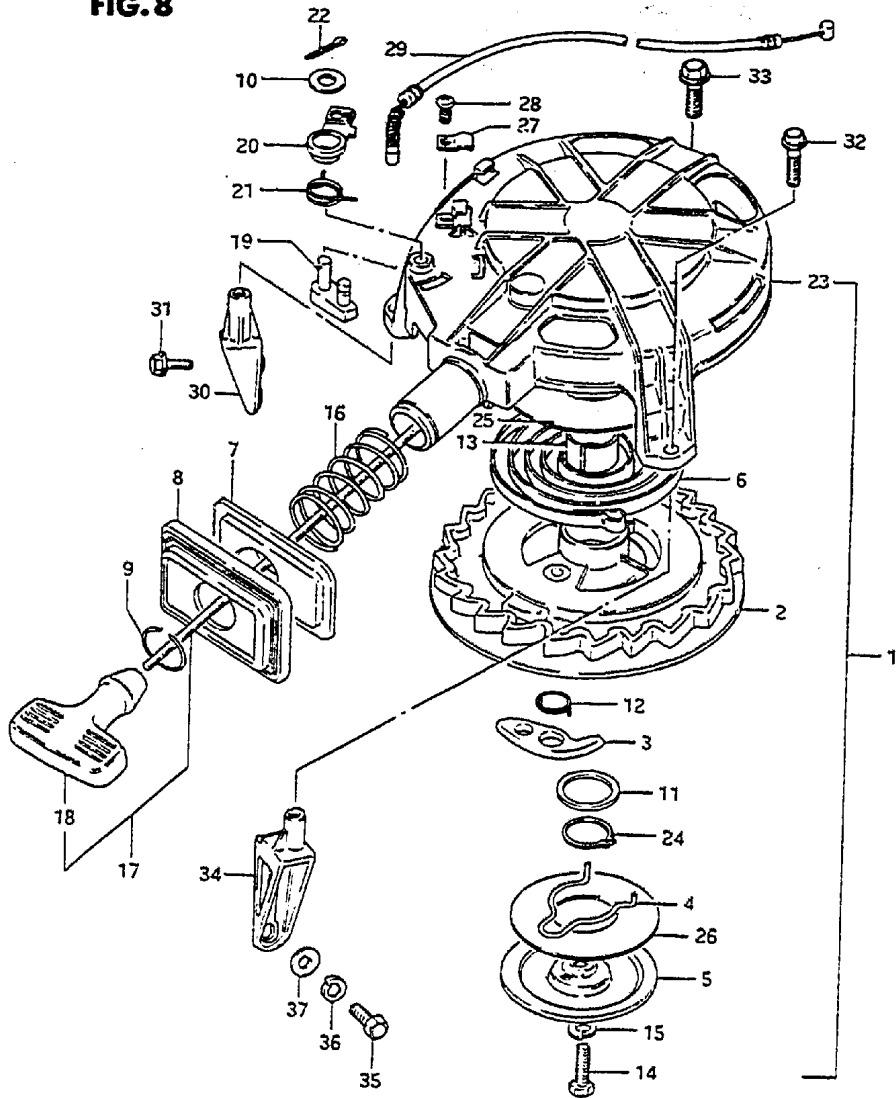

FIG.7 ( 8- 8) WATER PUMP

REF.NO.	PART NO.	DESCRIPTION	Q'TY	REMARKS
1	17411-94400	CASE, water pump	1	
2-1	17431-96310	TUBE, water pump seal (S)	1	
2-2	17431-96300	TUBE, water pump seal (L)	1	
3	17432-96300	GROMMET, seal tube	2	
4	17461-96301	WELLER, water pump	1	
5	17471-94	PANEL, under	1	
6	1747	GASKET, pump case, lower	1	
7-1		TUBE, water (S)	1	
7-2		TUBE, water (L)	1	
8	17553-96301	GROMMET, upper (1)	1	
9	17564-96301	GROMMET, upper (2)	1	
10	17565-96300	GROMMET, middle (S/L)	1	
11	17566-96302	GROMMET, lower	1	
12	09108-06007	STUD BOLT	4	
13	09140-06004	NUT	4	
14	09162-06006	LOCK WASHER	4	
15	09420-04006	KEY	1	
16	56130-96301-02M	HOUSING, drive shaft bearing	1	
17	25214-96302	BUSH	1	
18	09265-17002	BEARING	1	
19	09289-17004	OIL SEAL	1	
20	09100-06103	BOLT	2	
21	09162-06001	LOCK WASHER	2	
22	09280-50005	O RING	1	
23	17400-96350	KIT, water pump repair	1	OPT

FIG. 8 ( B- 9) RECOIL STARTER

FIG. 8



REF. NO.	PART NO.	DESCRIPTION	Q'TY	REMARKS
1	18100-96306	STARTER ASSY, recoil	1	
2	18120-96301	.REEL	1	
3	18131-96301	.RATCHET	1	
4	18153-96300	.SPRING	1	
5	18151-96301	.PLATE	1	
6	18142-96300	.SPRING	1	
7	18191-95202	.PLATE	1	
8	18192-95204	.RUBBER	1	
9	18195-95200	.RING	1	
10	18335-96300	.WASHER	1	
11	18162-96300	.WASHER	1	
12	18155-96301	.SPRING	1	
13	18124-96300	.BUSH	1	
14	18332-96300	.BOLT	1	
15	08321-31067	.LOCK WASHER	1	
16	18196-96301	.SPRING, protector	1	
17	18200-95203	.GRIP ASSY	1	
18	18210-93001	..GRIP	1	
19	18281-96300	.LEVER, stopper	1	
20	18282-96300	.ARM, stopper	1	
21	18284-96300	.SPRING	1	
22	18348-96300	.PIN	1	
23	18111-96301	.CASE, starter	1	
24	18255-96300	.CYRCLIP	1	
25	18144-96300	.SPACER	1	
26	18136-96300	.SPACER	1	
27	18291-96300	.HOLDER	1	
28	18342-96300	.SCREW	1	
29	18290-96301	CABLE, NSI	1	
30	18711-96303-02M	BRACE, recoil starter, STBD	1	
31	01517-06202	BOLT	2	
32	01517-06252	BOLT	2	
33	01517-08252	BOLT	1	
34	18721-96303-02M	BRACE, recoil starter, PORT	1	MANUAL STARTER
35	01107-08252	BOLT	2	MANUAL STARTER
36	08321-21082	LOCK WASHER	2	MANUAL STARTER
37	08322-11082	WASHER	2	MANUAL STARTER

FIG.9 ( C-2) CLUTCH

Q'TY

REF.NO.	PART NO.	DESCRIPTION	Q'TY	REMARKS
1	21210-96300	SHAFT, clutch	1	
2	09160-05010	WASHER (5.5x10x0.8)	1	
3	09204-01001	COTTER PIN	1	
4	09200-05006	PIN	1	
5	21311-96300	HOLDER, clutch shaft	1	
6	01517-06202	BOLT	4	
7	23111-96300	ROD, clutch	1	
8	09140-06004	NUT	1	
9-1	25111-96310	ROD, shift (S)	1	L:235
9-2	25111-96300	ROD, shift (L)	1	L:362
10	25222-96300	BOOT, shift rod	1	
11	09280-08005	O RING	1	
12	25211-96301	GUIDE, shift rod	1	
13	09280-13005	O RING	1	
14	09205-03021	SPRING PIN	1	
15	25215-96301	STOPPER, shift rod guide	1	
16	09139-04004	SCREW	2	
17	09205-02004	SPRING PIN	1	
18	25311-96303	CAM, shift	1	
19	23311-94300	TURN BUCKLE, clutch rod	1	
20	23131-94300	BOOT, clutch rod	1	
21	21111-96302-02M	LEVER, clutch	1	
22	09103-06093	BOLT (6x20)	1	
23	09260-10005	STEEL BALL	1	
24	09440-07021	SPRING	1	
25	09306-10001	BUSH	2	
26	21120-96301	PLATE, clutch notch	1	
27	09204-01002	COTTER PIN	2	
28	21241-96300	ROD, clutch arm	1	
29	25231-96301	SPACER, magnet	2	
30	25232-96301	MAGNET	1	
31	21121-93300	PLATE, clutch notch	1	

FIG.9

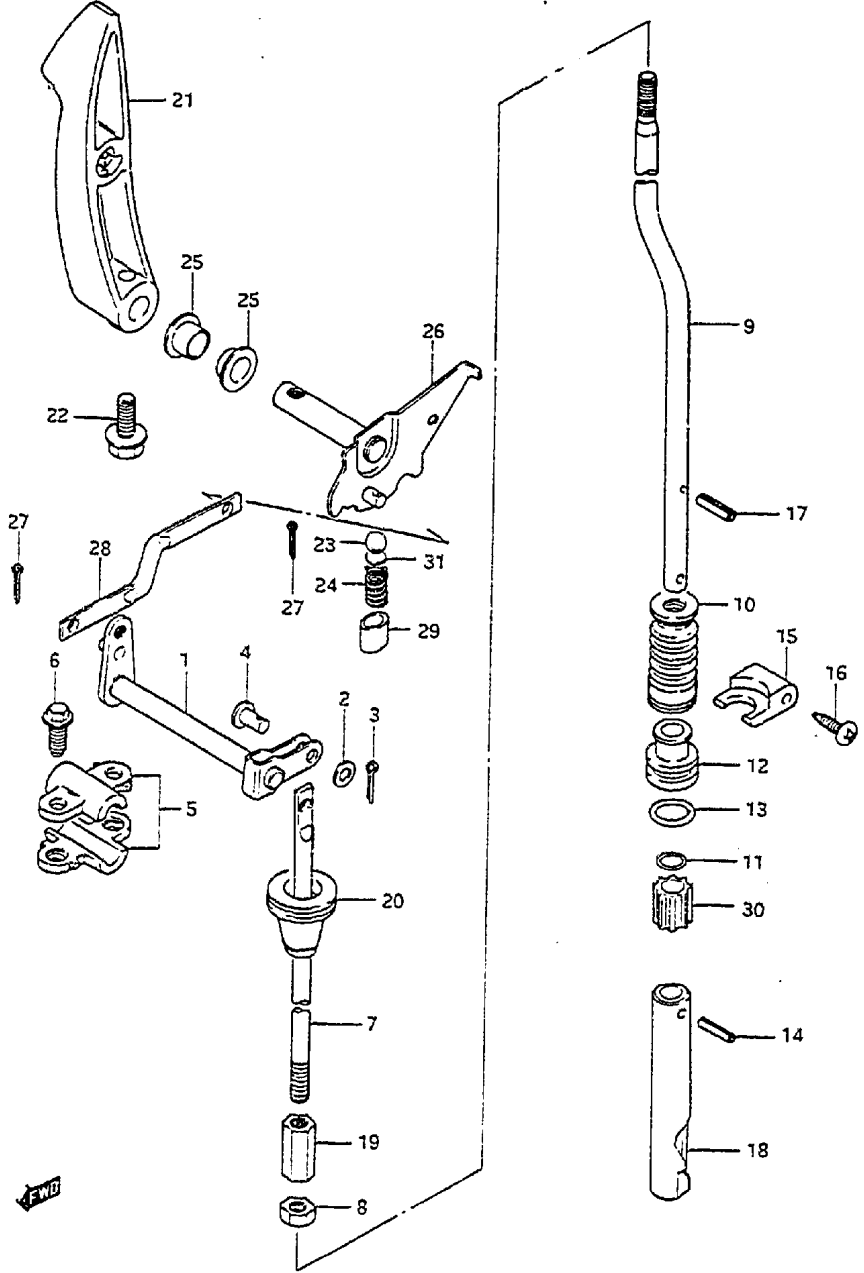

FIG. 10

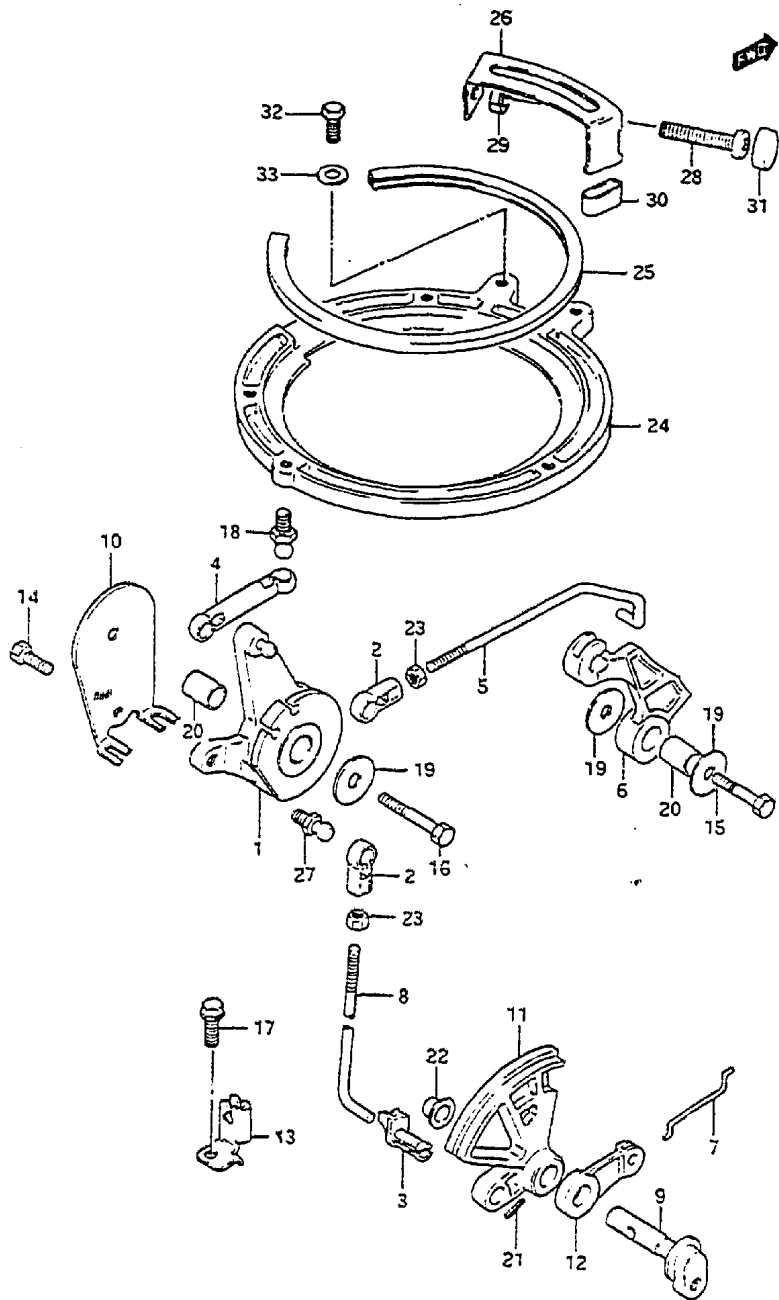

FIG.10 ( C- 3) THROTTLE CONTROL

REF.NO.	PART NO.	DESCRIPTION	Q'TY	REMARKS
1	19121-96301	LEVER, throttle control	1	
2	19131-95502	CONNECTOR, throttle lever	2	
3	19131-96300	RETAINER, rod connector	1	
4	19132-95500	CONNECTOR	1	
5	19135-96301	ROD	1	
6	19141-96301	CAM, throttle	1	
7	19654-96300	ROD	1	
8	19656-96300	ROD	1	
9	19720-96302	SHAFT, remo-con throttle	1	
10	19761-96300	STAY, throttle cable	1	
11	19811-96301-02M	LIMITER, throttle	1	
12	19851-96301	LEVER, NSI	1	
13	19861-96301	STAY, NSI cable	1	
14	09100-06131	BOLT	1	
15	09100-06083	BOLT (6x30)	1	
16	09100-06083	BOLT (6x30)	1	
17	09103-06049	BOLT (6x12)	1	
18	09119-05010	BALL PIVOT	1	
19	09160-06046	WASHER (6.5x20x1.5)	3	
20	09180-06105	SPACER (6.1x10x14)	2	
21	09205-04002	SPRING PIN	1	
22	09306-10001	BUSH	1	
23	08310-11052	NUT	2	
24	19151-96300-02M	RETAINER, stator	1	
25	19161-94301	SPACER, stator	1	
26	19172-96302	STOPPER, stator	1	
27	09119-05010	BALL PIVOT	1	
28	09139-06015	SCREW	1	
29	09140-06004	NUT	1	
30	09343-07140	CUSHION	1	
31	09329-06002	CUSHION	1	
32	01107-05102	BOLT	2	
33	08322-21052	WASHER	2	

FIG.11 ( C- 4) STARTING MOTOR

Q'TY

REF.NO.	PART NO.	DESCRIPTION	REMARKS
1	31100-96311	MOTOR ASSY, starter	1
2	31310-96300	.ARMATURE	1
3	31320-96300	.PINION	1
4	31312-96300	.STOPPER SET, pinion	1
5	31360-96300	.WASHER	1
6	31173-96301	.HOLDER ASSY, brush	1
7	31131-96300	..BRUSH (+)	1
8	31132-96300	..BRUSH (-)	1
9	31135-96300	..SPRING	2
10	31281-93340	.BOLT	2
11	01107-08252	BOLT	2
12	08321-21082	LOCK WASHER	2
13	08322-11082	WASHER	2
14	31800-94400	RELAY, starter	1 +31800-95502
15	31805-96350	BRACKET, starter relay	1
16	01107-06167	BOLT	1
17	08321-21067	LOCK WASHER	1
18	38422-94510	DAMPER, starter relay	1

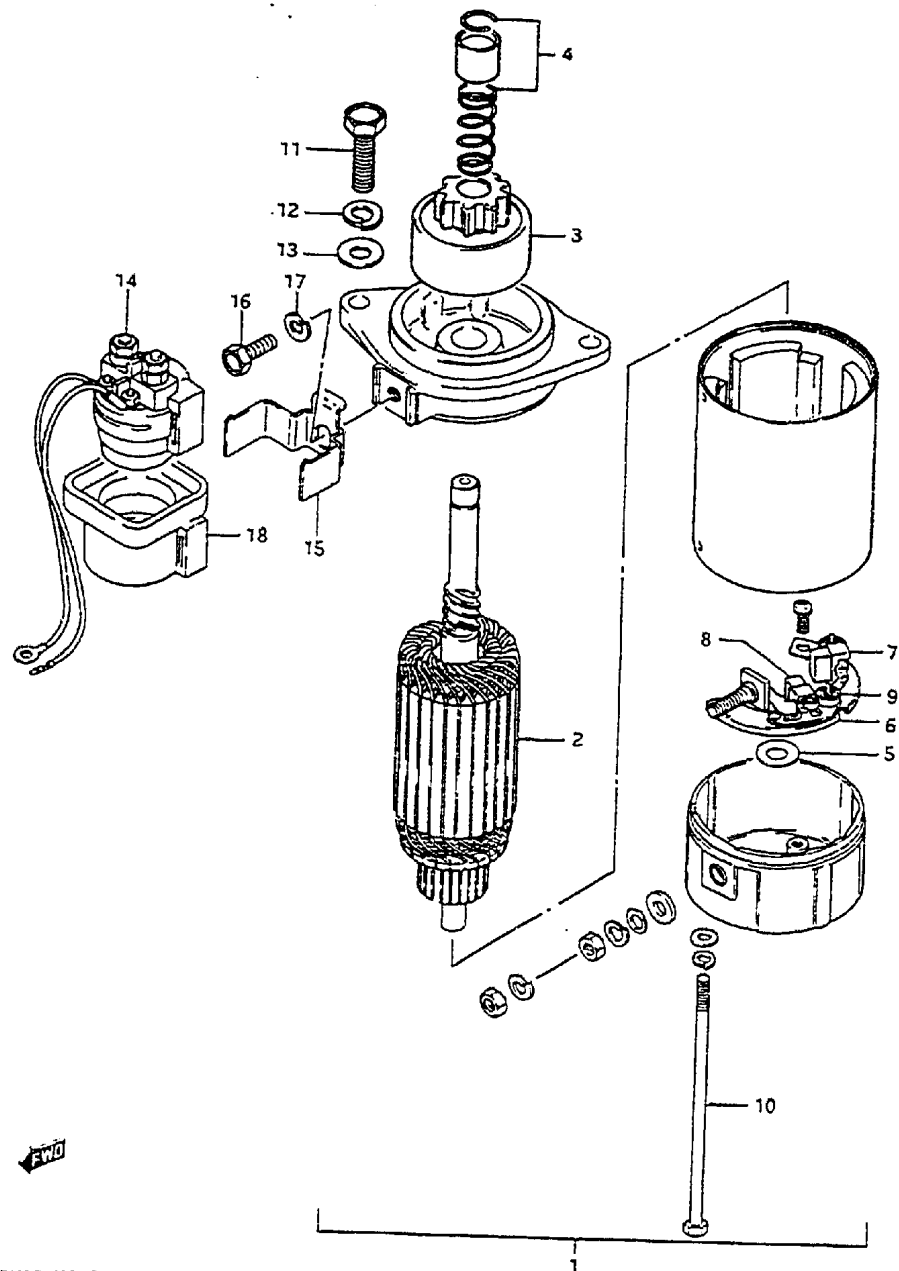

FIG. 12

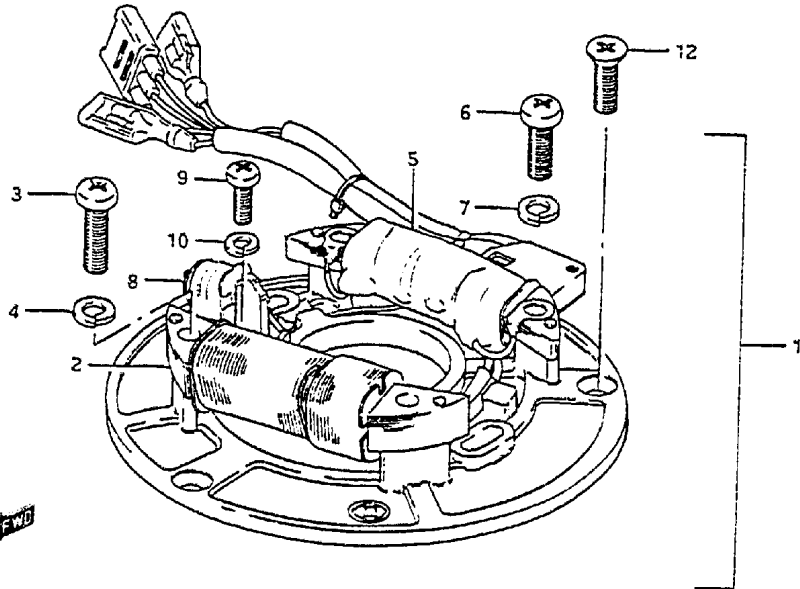
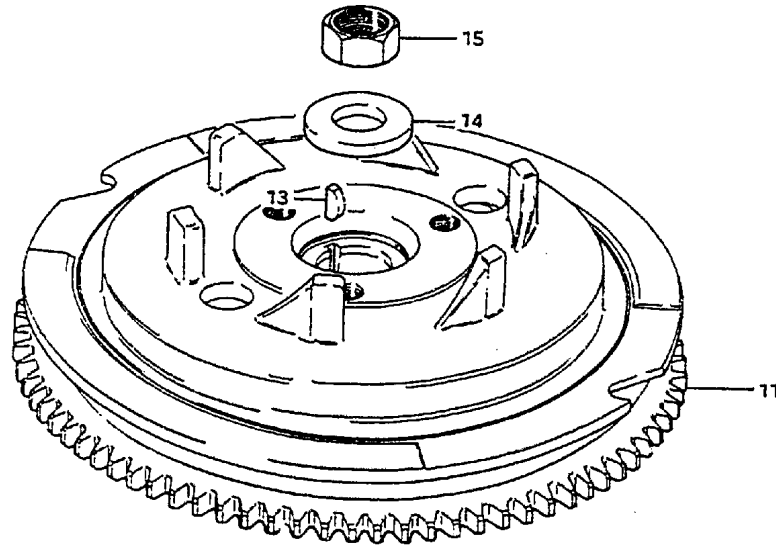

FIG.12 ( C- 5) MAGNETO

REF.NO.	PART NO.	DESCRIPTION	Q'TY	REMARKS
1	32101-96340	STATOR ASSY	1	
2-1	32120-96300	.COIL, lighting	1	for ELECTRIC STARTER
2-2	32120-96310	.COIL, lighting	1	for MANUAL STARTER
3	02112-05257	.SCREW	2	
4	08321-21057	.LOCK WASHER	2	
5	32140-96300	.COIL, ignition	1	
6	02112-05208	.SCREW	2	
7	08321-21057	.LOCK WASHER	2	
8	32150-96310	.SENSOR, ignition	1	
9	02112-04128	.SCREW	2	
10	08321-21047	.LOCK WASHER	2	
11	32102-96380	FLYWHEEL	1	
12	02122-05127	SCREW	3	
13	08341-31049	KEY	1	
14	09160-18011	WASHER (18.5x35x4)	1	
15	08310-22188	NUT	1	

FIG.13

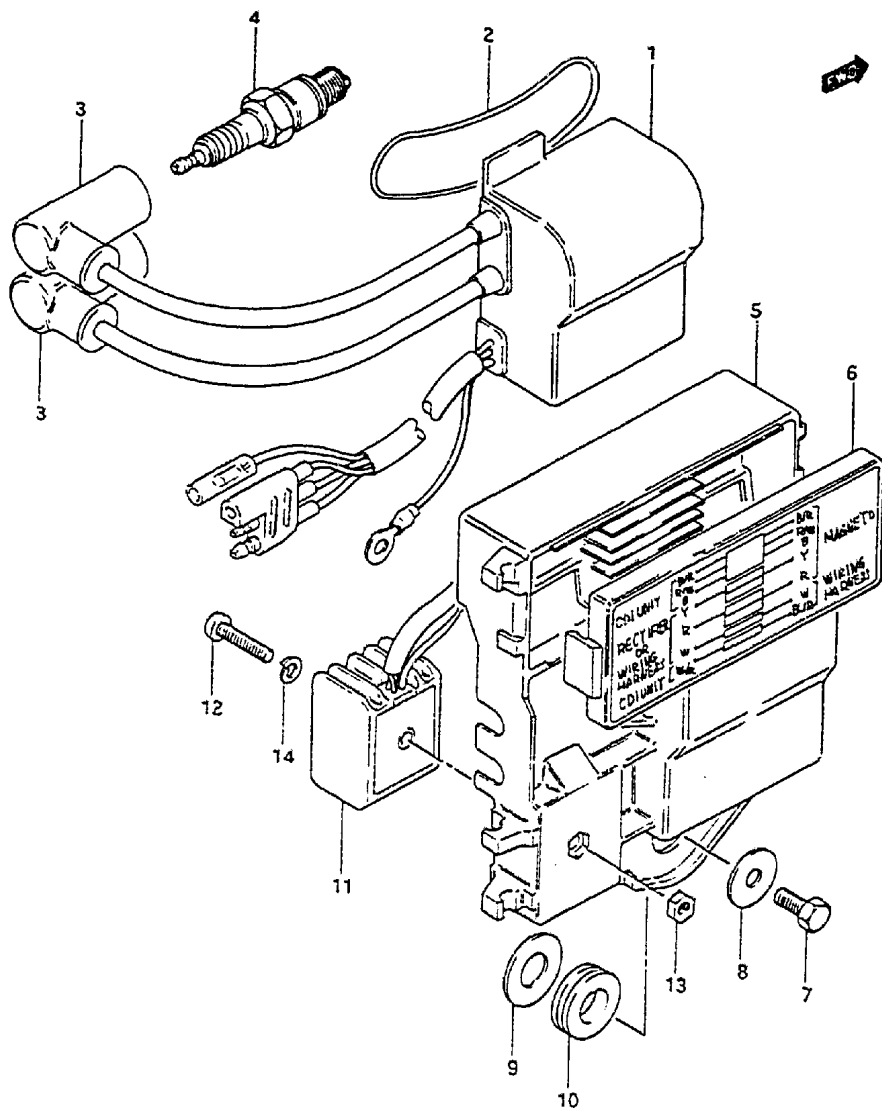

FIG.13 ( C-6) IGNITION

REF.NO.	PART NO.	DESCRIPTION	Q'TY	REMARKS
1	32900-96340	CDI. UNIT / IGNITION COIL ASSY	1	
2	09280-62001	O RING	1	
3	33510-95510	CAP, spark plug	2	
4	09482-00269	SPARK PLUG (B7HS)	2	
5	32890-96301	HOLDER, electric parts	1	
6	36650-96300	COVER, junction box	1	
7	01107-06122	BOLT	3	
8	09160-06054	WASHER	3	
9	09160-12056	WASHER	3	
10	09320-12011	CUSHION	3	
11	32800-95720	RECTIFIER	1	ELECTRIC STARTER
12	02112-05252	SCREW	1	ELECTRIC STARTER
13	08310-11052	NUT	1	ELECTRIC STARTER
14	08321-21052	LOCK WASHER	1	ELECTRIC STARTER

FIG.14

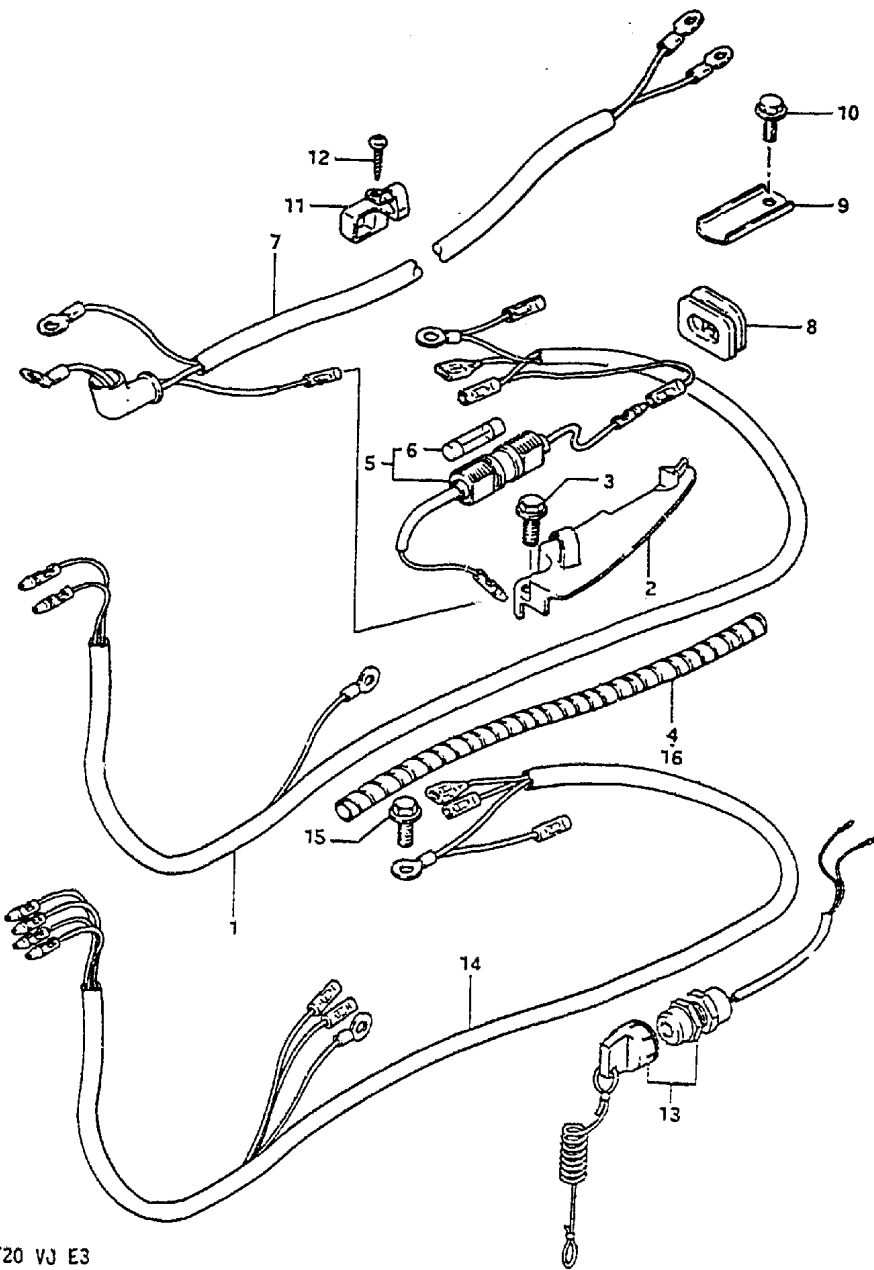

FIG.14 ( C- 7) ELECTRICAL

REF.NO.	PART NO.	DESCRIPTION	Q'TY	REMARKS
1	36610-96302	WIRING HARNESS	1	ELECTRIC STARTER
2	36619-96304	COVER, wiring harness	1	ELECTRIC STARTER
3	09103-06050	BOLT (6x16)	2	ELECTRIC STARTER
4	38423-95501	TUBE, wiring harness (L:150)	1	ELECTRIC STARTER
5	36740-95252	FUSE CASE ASSY	1	ELECTRIC STARTER
6	09481-20001	.FUSE (20A)	1	ELECTRIC STARTER
7	33810-96305	CABLE, starter	1	ELECTRIC STARTER
8	33811-96300	GROMMET, starter cable	1	ELECTRIC STARTER
9	33815-94501	PROTECTOR, cable	1	ELECTRIC STARTER
10	09103-06049	BOLT	1	ELECTRIC STARTER
11	33816-96300	CLAMP, starter cable	1	ELECTRIC STARTER
12	03242-06259	SCREW	1	ELECTRIC STARTER
13	37820-94420	SWITCH ASSY, emergency	1	
14	36899-96302	WIRING HARNESS	1	MANUAL STARTER
15	09103-06049	BOLT (6x12)	1	MANUAL STARTER
16-1	38423-95501	TUBE, wiring harness (L:150)	1	MANUAL STARTER
16-2	33833-95500	TUBE, wiring harness (L:100)	1	MANUAL STARTER



FIG. 15

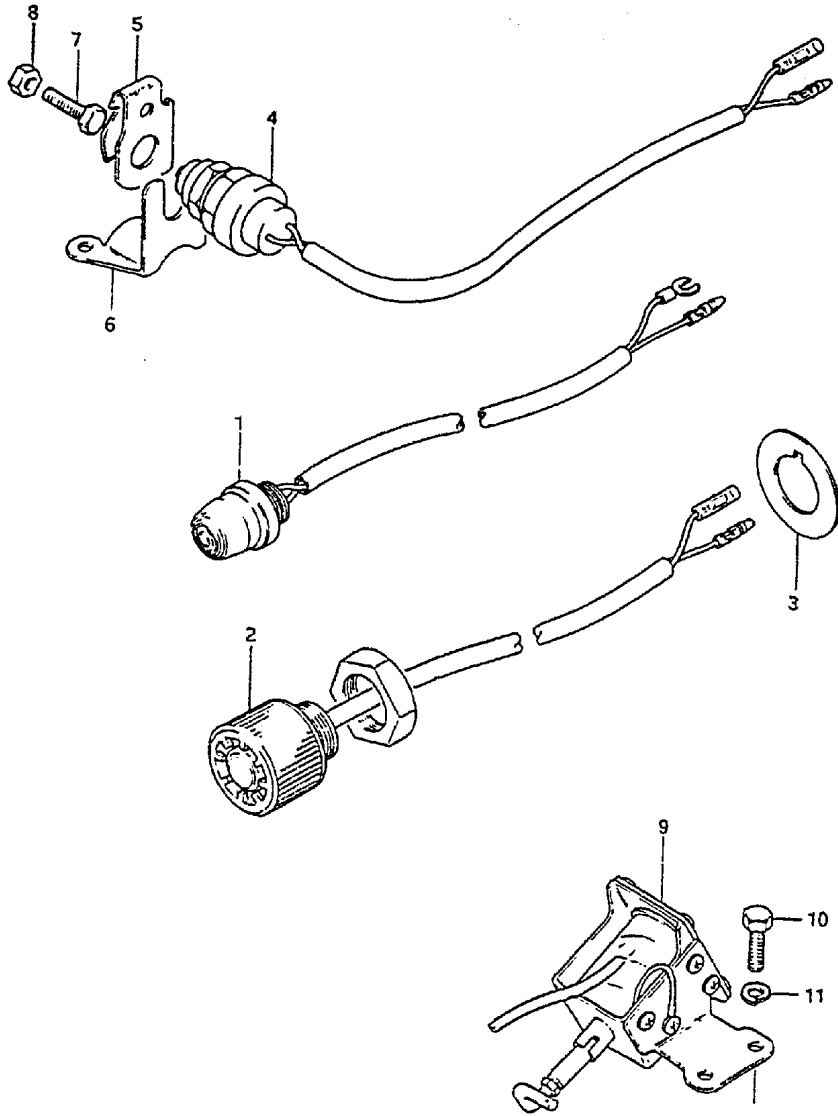

FIG.15 ( C- 8) ELECTRICAL (ELECTRIC STARTER)

REF.NO.	PART NO.	DESCRIPTION	Q'TY	REMARKS
1	37800-93950	SWITCH, stop	1	+37800-9635G
2	37160-96310	SWITCH, start	1	
3	37142-94302	WASHER, ignition switch	2	
4	37721-96354	SWITCH, neutral	1	
5	37725-95300	ACTUATOR, neutral switch	1	
6	37726-96302	BRACKET, neutral switch	1	
7-1	09106-05015	BOLT	1	model VG/VH
7-2	09100-05104	BOLT	1	model VJ
8-1	09140-05005	NUT	1	model VG/VH
8-2	09140-05001	NUT	1	model VJ
9	38600-96301	SOLENOID, choke	1	OPT (for REMO-CON)
10	09100-05004	BOLT (5x12)	2	OPT (for REMO-CON)
11	09162-05002	LOCK WASHER	2	OPT (for REMO-CON)

FIG. 16

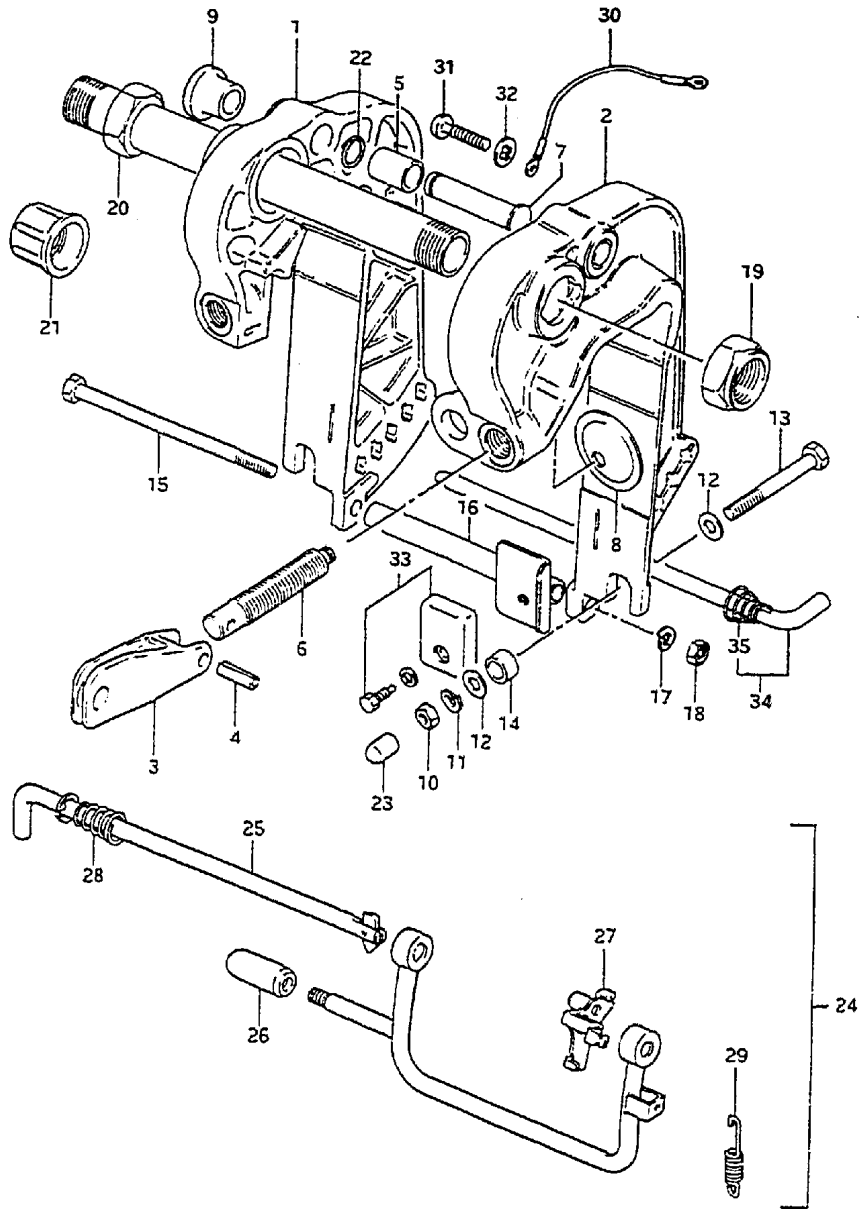

FIG.16 ( D- 2) CLAMP BRACKET

REF.NO.	PART NO.	DESCRIPTION	Q'TY	REMARKS
1	41110-96305-02M	BRACKET, clamp, STBD	1	
2	41120-96340-02M	BRACKET, clamp, PORT	1	
3	41212-93000-02M	HANDLE, clamp	2	
4	09205-06012	SPRING PIN	1	
5	09303-14002	BUSH	1	
6-1	41211-93910	SCREW, clamp (L:78)	2	OPT
6-2	41211-93920	SCREW, clamp (L:90)	2	
6-3	41211-93900	SCREW, clamp (L:68)	2	OPT
7-1	41222-96310	PIN, tilt stopper	1	-704965
7-2	41222-96311	PIN, tilt stopper	1	704966-
8	41213-98100	PLATE, clamp	2	
9	41221-96300	KNOB, tilt stopper	1	
10	09140-08016	NUT	2	
11	09162-08007	LOCK WASHER	2	
12	09160-08081	WASHER (8.5x23x1.5)	4	
13	09100-08239	BOLT (8x90)	2	
14	09180-09016	SPACER (9.2x13.8x9.5)	2	
15	09100-08196	BOLT (8x152)	1	
16-1	41310-96300	ROD, clamp bracket lower	1	model VG,VH
16-2	41310-96301	ROD, clamp bracket lower	1	model VJ
17	09162-08007	LOCK WASHER	1	
18	09140-08016	NUT	1	
19	09159-22003	NUT	1	
20	41130-96330	SHAFT, clamp bracket	1	
21	41151-94500	CAP	2	
22	09380-12005	SPRING	1	
23	41153-96300	CAP	2	
24	45700-96301	SHALLOW DRIVE ASSY	1	model VG/VH
25	45720-96301	.SHAFT	1	model VG/VH
26	45725-94400	.KNOB	1	model VG/VH
27	45730-96301	.PLATE	1	model VG/VH
28	09441-17001	.SPRING	1	model VG/VH
29	09443-08045	.SPRING	1	model VG/VH

FIG.16

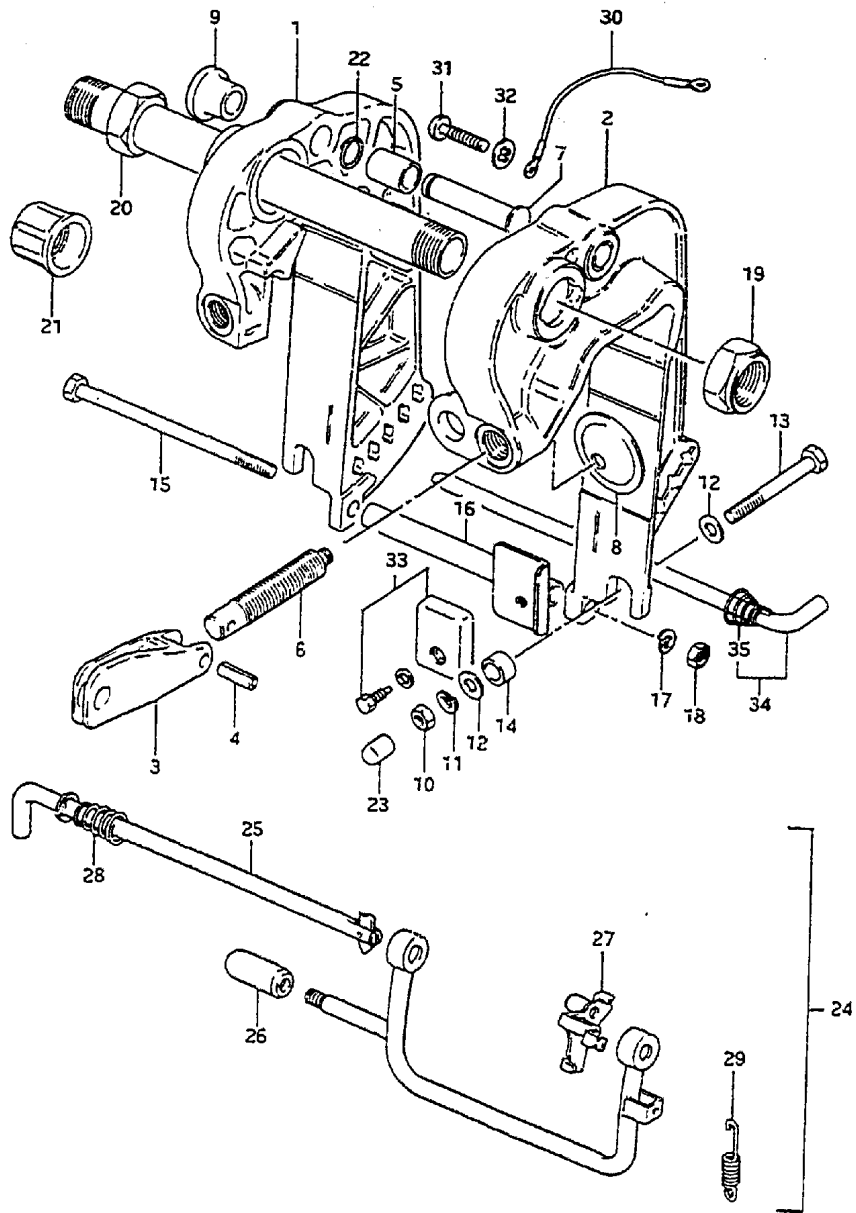

FIG.16 ( D-3) CLAMP BRACKET

REF.NO.	PART NO.	DESCRIPTION	Q'TY	REMARKS
30	36894-95200	LEAD	1	
31	09125-05050	SCREW	2	
32	09161-05014	WASHER	2	
33	55320-95310	ZINC, protection	1	
34	45420-96310	PIN, tilt lock	1	model VJ
35	09441-17001	-SPRING, tilt lock pin	1	model VJ

FIG.17

FIG.17 ( D- 4) SWIVEL BRACKET

Q'TY

REF.NO.	PART NO.	DESCRIPTION	Q'TY	REMARKS
1-1	43111-96311-02M	BRACKET, swivel	1	model VG/VH
1-2	43111-96320-02M	BRACKET, swivel	1	model VJ
2-1	22511-99001	NIPPLE, clutch body	4	model VG/VH
2-2	22511-99003	NIPPLE, clutch body	4	model VJ
3	43711-96301	BUSH, steering upper	1	
4	43712-96301	BUSH, steering under	1	
5	43721-96301	PLATE, upper bush	1	
6	43741-96302-02M	SHAFT, pilot	1	
7-1	43751-96303-02M	BRACKET, steering	1	model VG/VH
7-2	43751-96304-02M	BRACKET, steering	1	model VJ
8	09160-40005	WASHER (40x58x2)	1	
9	09306-22004	BUSH	2	
10	09100-08219	BOLT	4	
11	09162-08003	LOCK WASHER	4	
12	43411-96300	ADJUSTER, steering	1	
13	43421-96301	BUSH	1	
14	09119-08044	BOLT	1	
15	09440-13045	SPRING	1	
16	45231-96303	ARM, reverse lock	1	
17-1	45246-96301	SPACER	1	model VG/VH
17-2	45246-96302	SPACER	1	model VJ
18	45241-96303	LINK, reverse lock arm	1	
19	45252-96302	LINK, release lever	1	
20	45255-96300	KNOB, release lever	1	
21	45257-96300	BUSH, release lever	1	

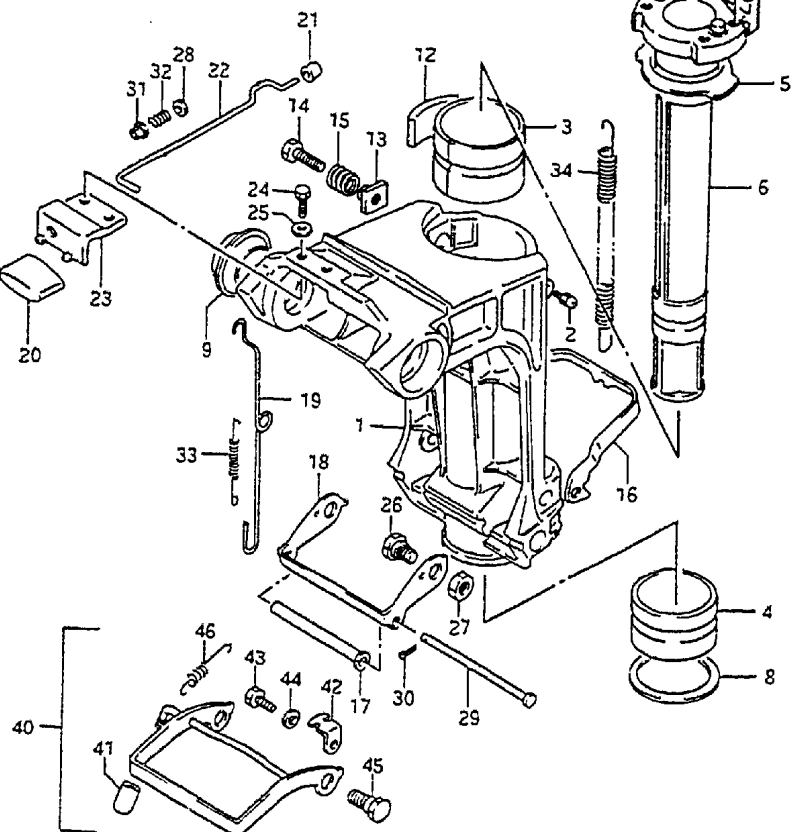
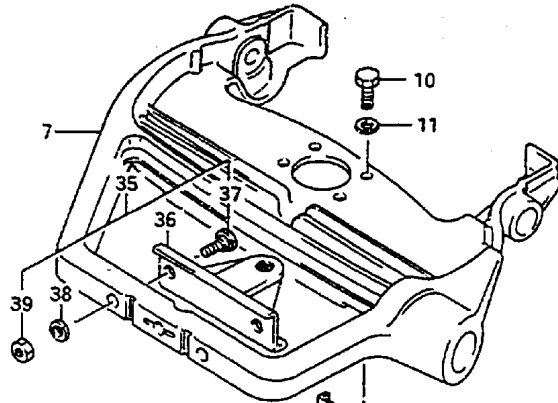
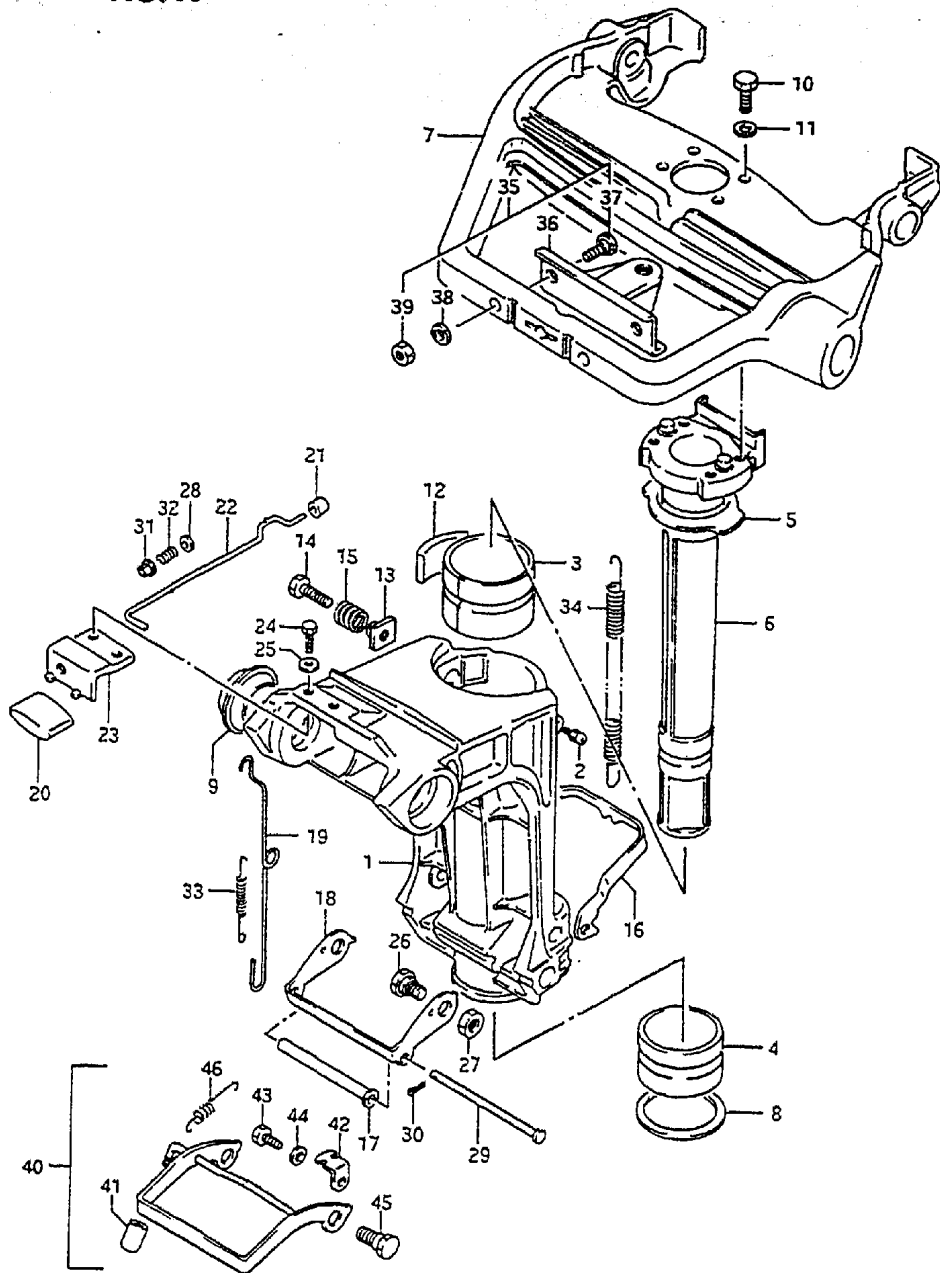

FIG. 17

FIG. 17 ( D- 5) SWIVEL BRACKET



REF.NO.	PART NO.	DESCRIPTION	Q'TY	REMARKS
22	45260-96300	LEVER, release	1	
23	45311-96302-02M	BRACKET, release lever	1	
24	09100-05011	BOLT (5x12)	2	
25	09160-05010	WASHER	2	
26	09111-10034	BOLT	2	
27	09140-10032	NUT	2	
28	09160-04012	WASHER (4.2x10x1)	1	
29	09200-05011	PIN	1	
30	09204-01001	COTTER PIN	1	
31	09319-04001	BUSH	1	
32	09440-04021	SPRING	1	
33	09443-05013	SPRING	1	
34	09443-09036	SPRING	1	
35	67100-96300	ATTACHMENT SET	1	OPT
36	43755-96301	.ATTACHMENT, steering bracket	1	OPT
37	09100-08224	.BOLT (8x35)	2	OPT
38	09162-08007	.LOCK WASHER	2	OPT
39	09140-08016	.NUT	2	OPT
40	45700-96311	SHALLOW DRIVE ASSY	1	model VJ
41	45255-95500	.KNOB	1	model VJ
42	45731-96310	.PLATE	1	model VJ
43	09100-06113	.BOLT	1	model VJ
44	09162-06001	.LOCK WASHER	1	model VJ
45	09111-10032	.BOLT	2	model VJ
46	09443-08031	.SPRING	1	model VJ

FIG.18 ( D- 6) EXHAUST TUBE

FIG.18

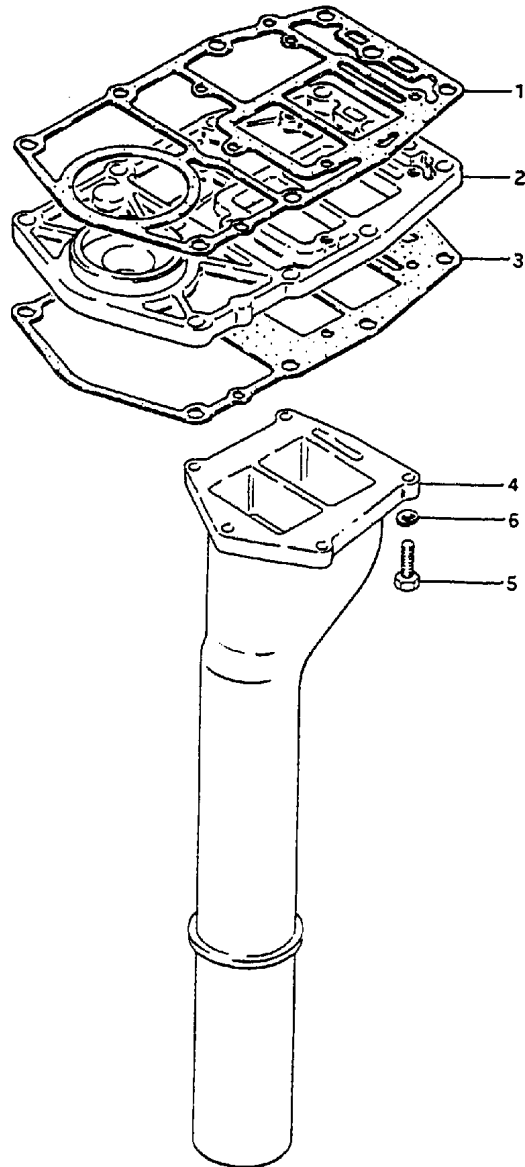

REF.NO.	PART NO.	DESCRIPTION	Q'TY	REMARKS
1	11433-96302	GASKET, lower oil seal housing	1	
2	11431-96310	HOUSING, under oil seal	1	
3	52113-96304	GASKET, drive shaft housing	1	
4-1	14211-96330	TUBE, exhaust (S)	1	
4-2	14211-96320	TUBE, exhaust (L)	1	
5	09100-06117	BOLT (6x35)	5	
6	09162-06001	LOCK WASHER	5	

FWB

FIG. 19

FIG. 19 ( D- 7) DRIVESHAFT HOUSING

Q'TY

REF.NO.	PART NO.	DESCRIPTION	Q'TY	REMARKS
1	09202-06015	PIN	2	
2	09160-08015	WASHER	8	
3	09162-08003	LOCK WASHER	8	
4	09100-08203	BOLT (8x85)	4	
5	09100-08204	BOLT (8x50)	4	
6-1	52111-96321-02M	HOUSING, drive shaft,S	1	~604319
6-2	52111-96322-02M	HOUSING, drive shaft,S	1	604320-705873
6-3	52111-96323-02M	HOUSING, drive shaft,S	1	805874-
6-4	52111-96330-02M	HOUSING, drive shaft,L	1	~604319
6-5	52111-96331-02M	HOUSING, drive shaft,L	1	604320-705873
6-6	52111-96332-02M	HOUSING, drive shaft,L	1	805874-
7	52117-94400	TUBE, WATER INSPECTION	1	604320-
8	54121-96300	MOUNTING, upper thrust reverse	1	
9	09100-06102	BOLT	4	
10	09162-06001	LOCK WASHER	4	
11	54137-96301-02M	COVER, upper mounting	2	
12	54130-96310	MOUNTING, upper	2	
13	09100-10260	BOLT (10x75)	2	
14	09160-10082	WASHER (10.5x19x2)	4	
15	09159-10050	NUT	2	
16	54160-96310	MOUNTING, lower	2	
17	54165-96310	DAMPER, reverse stopper	2	
18	54166-96301	BOLT, lower mounting	2	
19	09140-10032	NUT	2	
20	09160-10083	WASHER (10.5x30x3.2)	2	

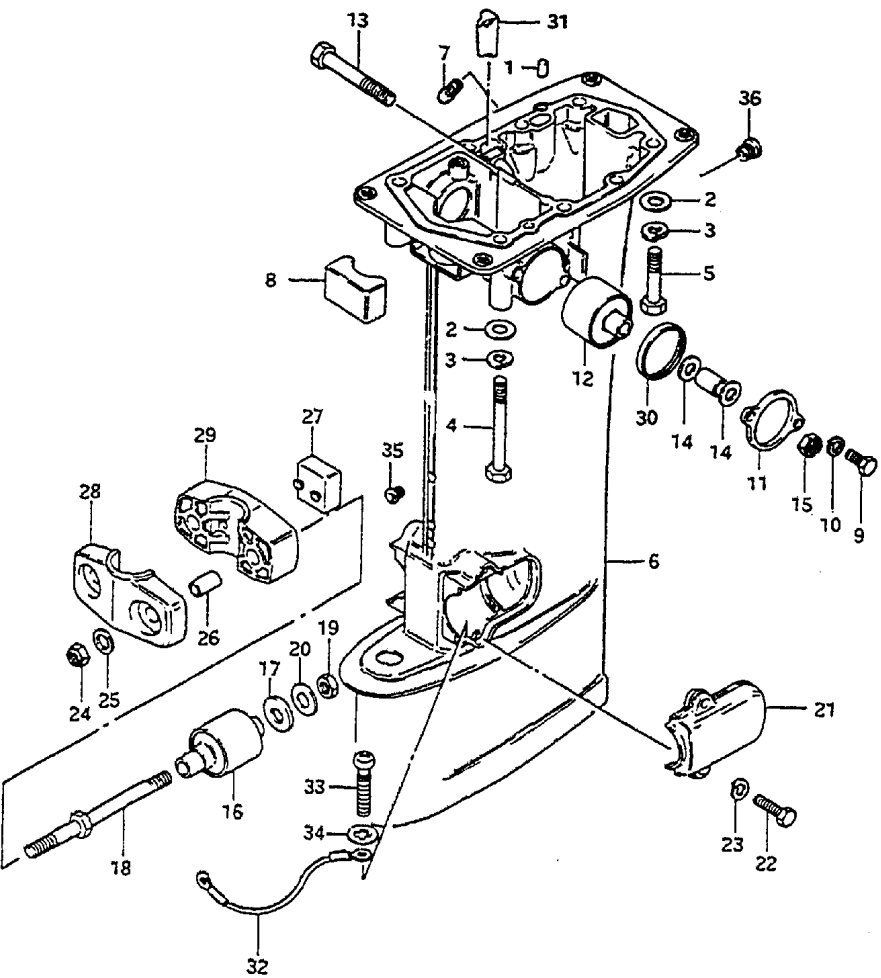

FIG. 19

FIG. 19 ( D- 8) DRIVESHAFT HOUSING

Q'TY

REF.NO.	PART NO.	DESCRIPTION	Q'TY	REMARKS
21	54221-96301-02M	COVER, lower mounting	2	
22	09100-06104	BOLT	4	
23	09162-06001	LOCK WASHER	4	
24	09159-10050	NUT	2	
25	09160-10082	WASHER (10.5x19x2)	2	
26	09180-10102	SPACER	2	
27	54151-96300	MOUNTING, lower thrust	1	
28	54211-96310-02M	BRACKET, lower mount forward	1	
29	54212-96302-02M	BRACKET, lower mount aft	1	
30	54138-96300	SLEEVE, upper mounting	2	
31	17568-96300	PLUG	1	
32	36894-95200	LEAD	1	
33	09125-05050	SCREW	2	
34	09161-05014	WASHER	2	
35	52124-93900	BUSH, driveshaft HOUS, No.1	3	model VJ
36	52125-96300	BUSH, driveshaft HOUS, No.2	2	model VJ

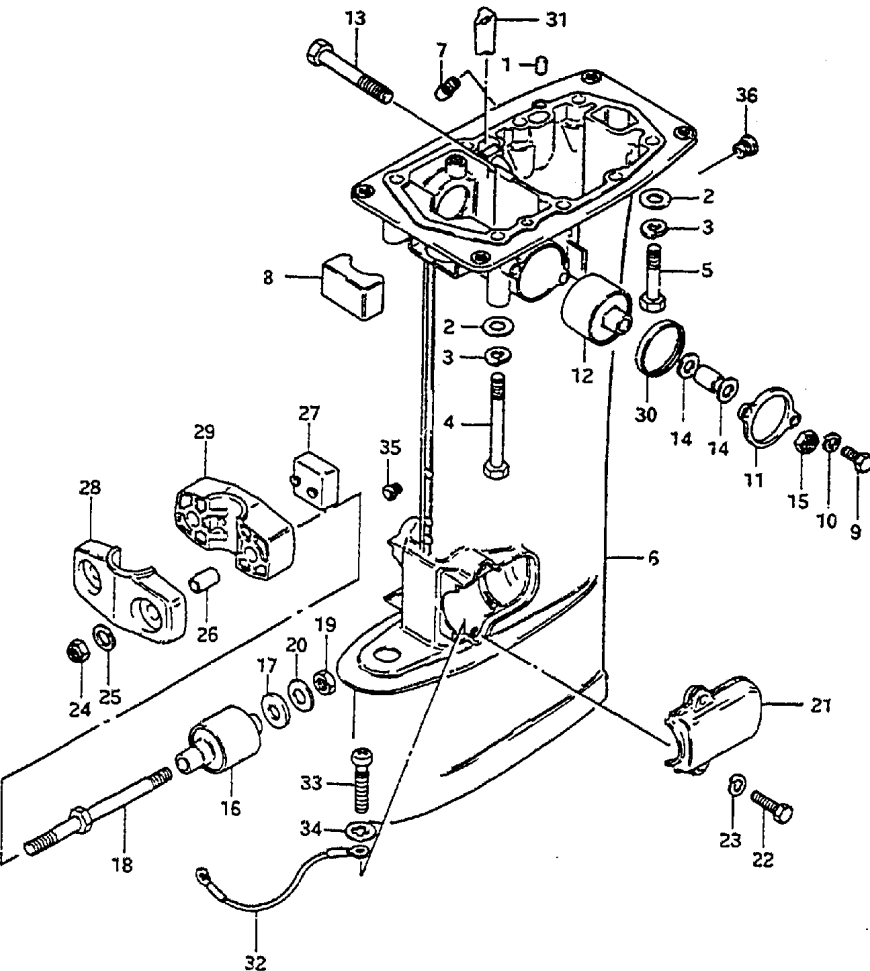



FIG. 20

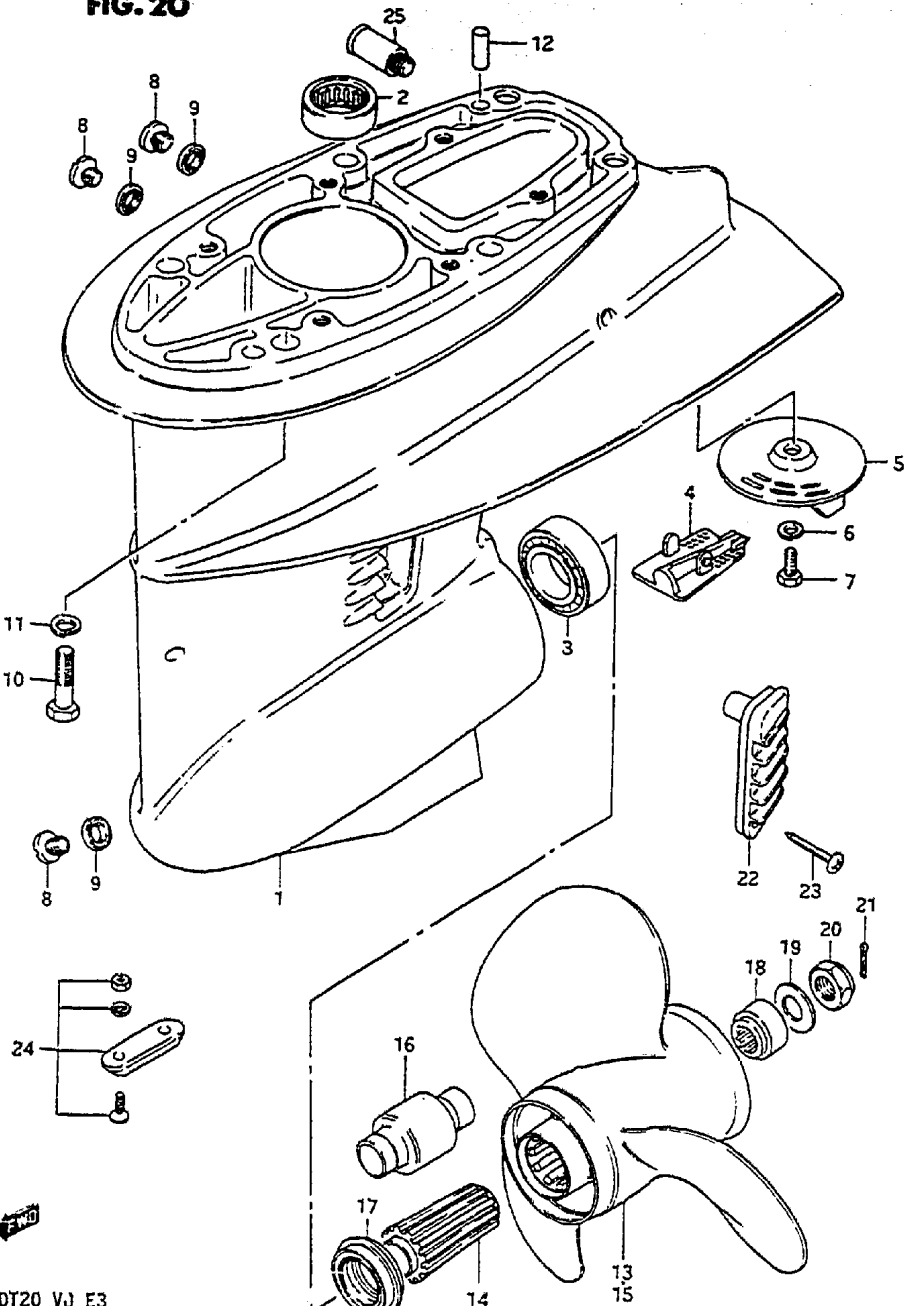

FIG. 20 ( D- 9) GEAR CASE

REF.NO.	PART NO.	DESCRIPTION	Q'TY	REMARKS
1	55100-96301-02M	CASE ASSY, gear	1	
2	09263-20046	.BEARING (20.63x26.98x25.4)	1	
3	09263-25015	.BEARING	1	
4	55114-96301	.COVER, gear case	1	
5	55125-96302	TRIM TAB	1	
6	09162-08003	LOCK WASHER	1	
7	09100-08215	BOLT (8x20)	1	
8	09248-10005	PLUG	3	
9	09168-10022	GASKET (10x17x1.5)	3	
10	09100-08224	BOLT (8x35)	6	
11	09162-08003	LOCK WASHER	6	
12	09202-06015	PIN	2	
13-1	58110-96301-01T	PROPELLER (3x10-1/4x9)	1	P900
13-2	58110-96312-01T	PROPELLER (3x10-1/4x10)	1	P1000
13-3	58110-96321-01T	PROPELLER (3x10-1/4x11)	1	P1100
13-4	58110-96331-01T	PROPELLER (3x10-1/4x12)	1	P1200,L TYPE:STD 86 model
13-5	58110-96341-01T	PROPELLER (3x10-1/4x13)	1	P1300,S TYPE:STD 86 model
13-6	58110-96351-01T	PROPELLER (3x10-1/4x14)	1	P1400
13-7	58110-96361-01T	PROPELLER (3x10-1/4x15)	1	P1500
14	58120-96313	BUSH	1	
15-1	58100-96400-01T	PROPELLER (3x10-1/4x9)	1	P901
15-2	58100-96410-01T	PROPELLER (3x10-1/4x10)	1	P1001
15-3	58100-96420-01T	PROPELLER (3x10-1/4x11)	1	P1101
15-4	58100-96430-01T	PROPELLER (3x10-1/4x12)	1	P1201,L TYPE:STD 87/88 model
15-5	58100-96440-01T	PROPELLER (3x10-1/4x13)	1	P1301,S TYPE:STD 87/88 model
15-6	58200-96400	PROPELLER (3x10-1/4x13)	1	PS1300, stainless steel
15-7	58100-96450-01T	PROPELLER (3x10-1/4x14)	1	P1401
15-8	58100-96460-01T	PROPELLER (3x10-1/4x15)	1	P1501
16	58120-96400	.BUSH	1	

FIG. 20

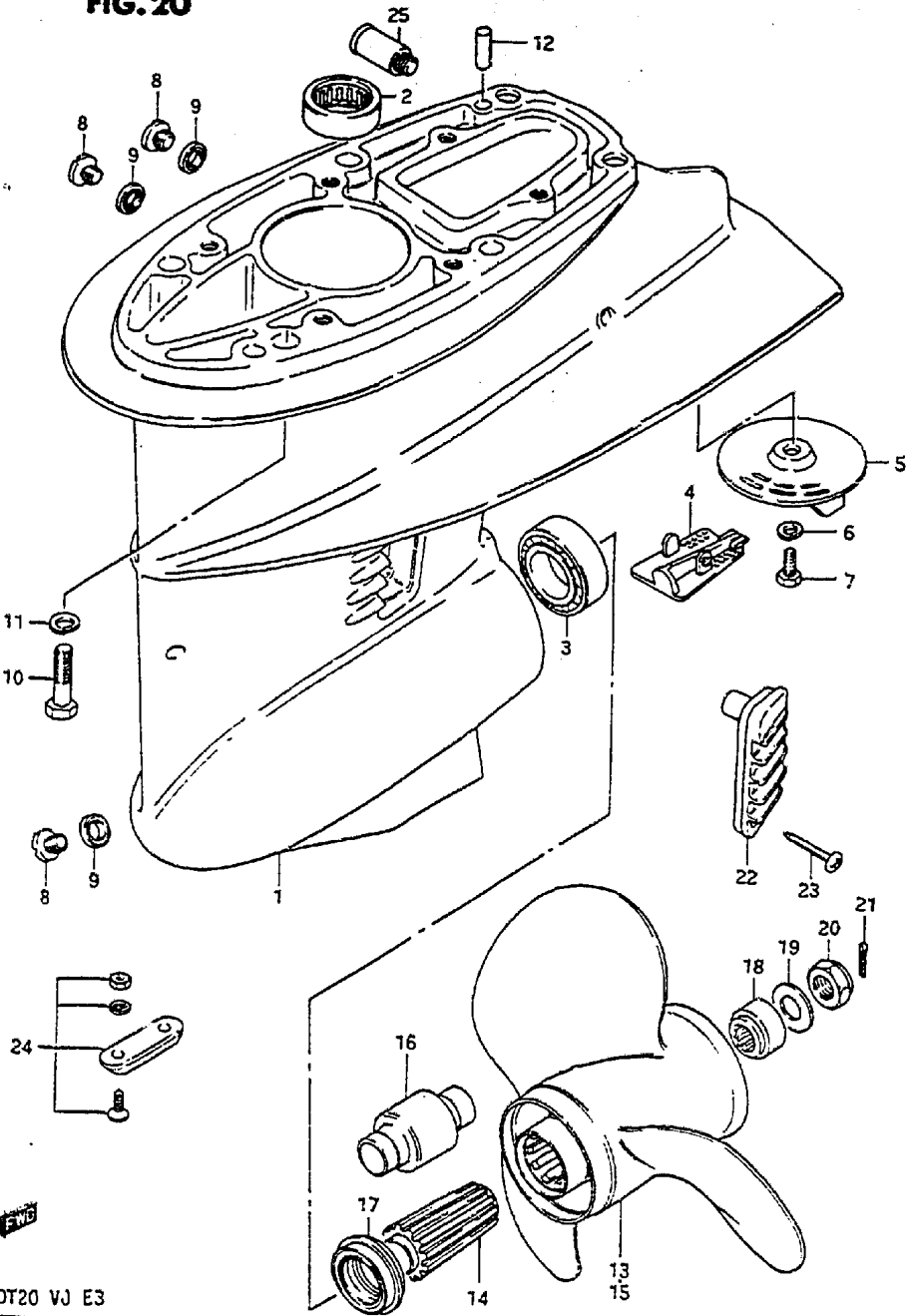
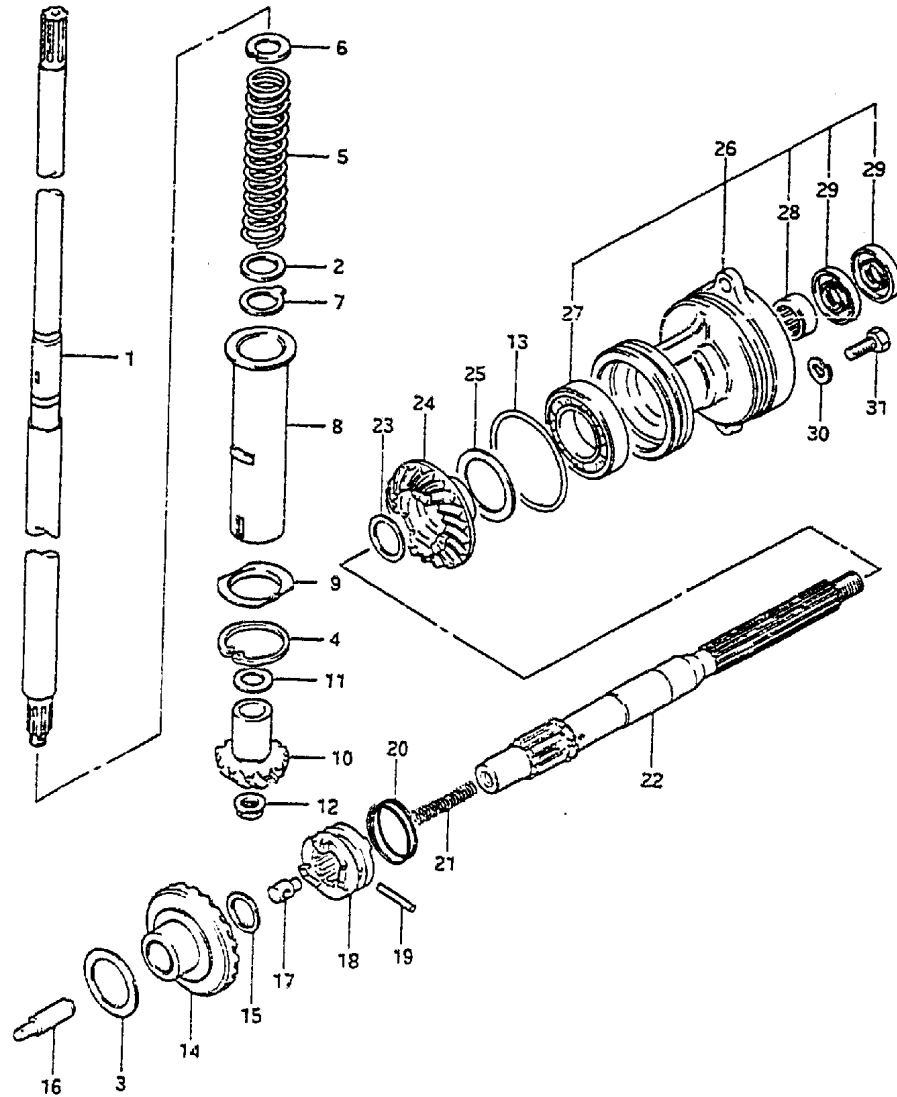

FIG. 20 ( D-10) GEAR CASE

REF. NO.	PART NO.	DESCRIPTION	Q'TY	REMARKS
17-1	57632-96312	STOPPER, propeller bush	1	for Ref.No.15
17-2	57632-96400	STOPPER, propeller bush	1	for Ref.No.15
18	57633-96300	SPACER	1	
19	09160-14028	WASHER (14.5x30x2.5)	1	
20	09159-14011	NUT	1	
21	09204-03004	COTTER PIN	1	
22	17631-96310	FILTER, water	2	
23	03142-04259	SCREW	2	
24	55300-95500	ZINC ASSY, protection	1	OPT
25	55181-95200	ATTACHMENT, flush hose	1	OPT
<b>OPTIONAL PROPELLERS</b>				
	58100-96370-019	PROPELLER (3X10 1/4X9)	1	OPT, Heavy Duty, Press in bushing
	58100-96470-019	PROPELLER (3X10 1/4X10)	1	OPT, Heavy Duty, Press in bushing
	58100-96480-019	PROPELLER (3X10 1/4X12)	1	OPT Heavy Duty, Press in bushing
	58100-96490-019	PROPELLER (3X10 1/4X13)	1	OPT Heavy Duty, Press in bushing
<b>GEARCASE ASSEMBLY (NOT SHOWN)</b>				
	50001-96817-02M	GEAR CASE ASSEMBLY	1	OPT, short (15")
	50002-96817-02M	GEAR CASE ASSEMBLY	1	OPT, long (20")

FIG. 21

FIG. 21 ( 0-11) TRANSMISSION



REF.NO.	PART NO.	DESCRIPTION	Q'TY	REMARKS
1-1	57110-96311	SHAFT, drive (S)	1	
1-2	57110-96301	SHAFT, drive (L)	1	
2	08211-20253	THRUST WASHER	1	
3-1	08221-25366	WASHER (T:0.8)	1	
3-2	09181-25022	WASHER (T:0.9)	1	
3-3	08211-25401	WASHER (T:1.0)	0-1	
3-4	09160-25032	WASHER (T:1.1)	0-1	
3-5	09160-25033	WASHER (T:1.2)	0-1	
3-6	09160-25034	WASHER (T:1.3)	0-1	
3-7	09160-25035	WASHER (T:1.4)	0-1	
3-8	08211-25402	WASHER (T:1.5)	0-1	
4	08331-21409	CIRCLIP	1	
5	09440-25002	SPRING	1	
6	09166-17005	WASHER	1	
7	09167-20021	WASHER	1	
8	57133-96302	SPACER, preload spring	1	
9	57134-96301	BARRIER	1	
10	57311-96310	PINION	1	
11-1	09160-15030	WASHER (T:1.7)	0-1	
11-2	09160-15031	WASHER (T:1.8)	0-1	
11-3	09160-15032	WASHER (T:1.9)	0-1	
11-4	08211-15203	WASHER (T:2.0)	0-1	
11-5	09160-15033	WASHER (T:2.1)	0-1	
11-6	08211-15204	WASHER (T:2.2)	0-1	
12	09159-08046	NUT	1	
13	09280-75002	O RING	1	
14	57510-96312	GEAR, forward	1	
15	08211-16242	WASHER (T:1.5)	1	
16	57631-96301	ROD, push	1	
17	09209-08016	PIN	1	

FIG. 21

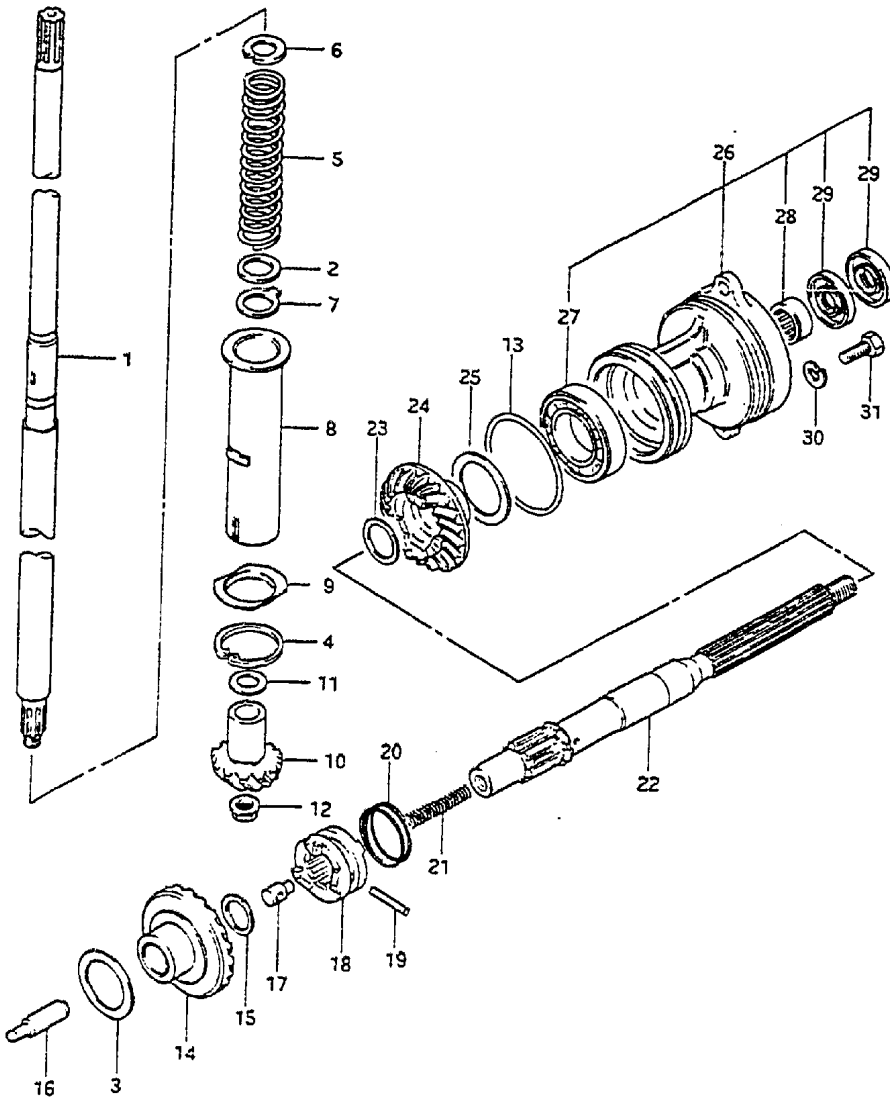

FIG. 21 ( D-12) TRANSMISSION

REF. NO.	PART NO.	DESCRIPTION	Q'TY	REMARKS
18	57621-96300	SHIFTER, clutch dog	1	
19	09202-05021	PIN	1	
20	09440-35004	SPRING	1	
21	09440-07041	SPRING	1	
22	57610-96303	SHAFT, propeller	1	
23-1	08221-20256	WASHER (T:0.8)	0-1	
23-2	09160-20035	WASHER (T:0.9)	0-1	
23-3	08211-20251	WASHER (T:1.0)	0-1	
23-4	09160-20036	WASHER (T:1.1)	0-1	
23-5	09160-20037	WASHER (T:1.2)	0-1	
23-6	09160-20038	WASHER (T:1.3)	0-1	
24	57521-96311	GEAR, reverse	1	
25-1	08211-30401	THRUST WASHER (T:1)	0-1	
25-2	08221-30404	THRUST WASHER (T:0.2)	0-2	
25-3	08221-30405	THRUST WASHER (T:0.5)	0-1	
25-4	08221-30406	THRUST WASHER (T:0.8)	0-1	
26	56120-96311-02M	HOUSING, propeller shaft brg	1	
27	08113-60060	.BEARING	1	
28	09263-20047	.BEARING (20x26x20)	1	
29	09289-20009	.OIL SEAL (20x34x6.5)	2	
30	09162-06001	LOCK WASHER	2	
31	09100-06136	BOLT	2	

FIG. 22

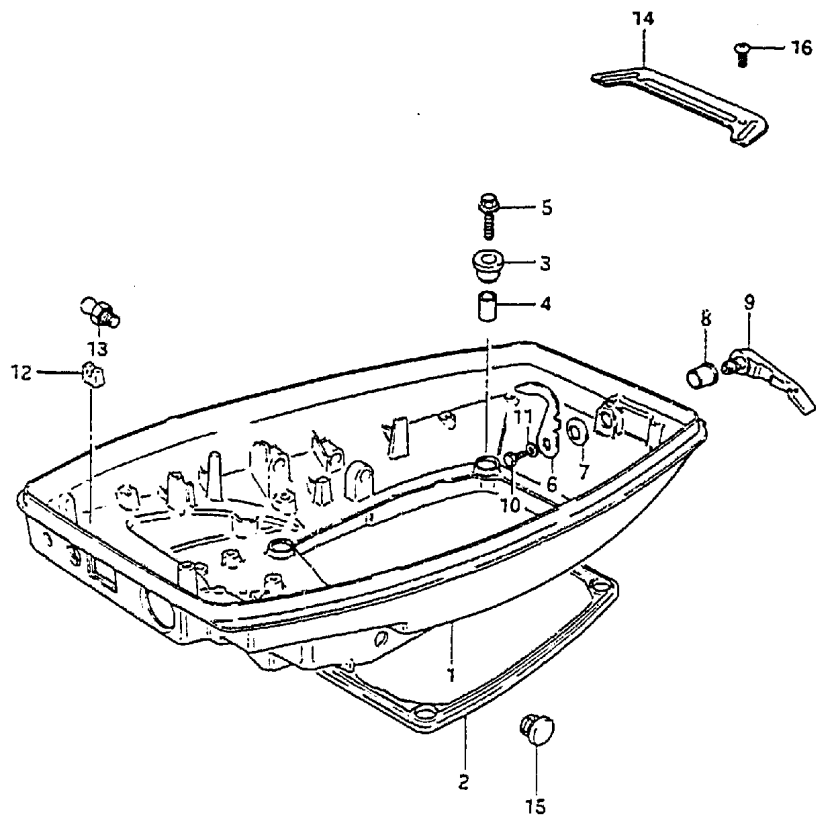

FIG. 22 ( E- 2) UNDER COVER

REF.NO.	PART NO.	DESCRIPTION	Q'TY	REMARKS
1	61110-96304-02M	COVER, engine under	1	
2	61113-96300	SEAL, under cover	1	
3	09320-10031	CUSHION, under cover	4	
4	09180-06112	SPACER (6.8x10x11.5)	4	
5	09103-06094	BOLT	4	
6-1	61631-96301	HOOK, under cover	1	model VG/VH
6-2	61631-94410	HOOK, under cover	1	model VJ
7	09164-13005	WASHER	1	
8	09306-13002	BUSH	1	
9	61633-96002-02M	LEVER, hook	1	
10	01107-06102	BOLT	1	
11	08322-21062	WASHER	1	
12	13625-94300	CAP	1	
13-1	22511-99001	NIPPLE	1	model VG, VH
13-2	22511-99003	NIPPLE	1	model VJ
14	61138-96301	COVER, washer	1	
15	09250-08007	CAP, cushion	2	
16	09125-06069	BOLT	2	



FIG. 23

FIG. 23 ( E- 3) ENGINE COVER

Q'TY

REF.NO.	PART NO.	DESCRIPTION	Q'TY	REMARKS
1-1	61401-96820-02M	COVER SET, engine	1	model VG/VH
1-2	61401-96821-02M	COVER SET, engine	1	model VJ
2	61431-96301-02M	.HANDLE, tilt up	1	
3	03242-05169	.SCREW	3	
4	61422-93930-70G	.MARK, emblem, front	1	
5	61443-96400-26G	.DECAL, side RH	1	
6	61453-96400-26G	.DECAL, side LH	1	
7	61435-96400-70G	.EMBLEM, rear	1	
8	21131-96003	.MARK, clutch shift	1	
9	61441-96310	.EMBLEM, side	2	
10-1	61610-96302	.FASTENER	1	model VG/VH
10-2	61610-96310	.FASTENER	1	model VJ
11	01107-06122	.BOLT	1	
12	08321-21062	.LOCK WASHER	1	
13	08322-21062	.WASHER	1	
14	61112-96302	RUBBER, under cover	1	
15	61622-96301	RUBBER, recoil starter seal	1	
16	68110-95210	COVER, weather	1	OPT
17	09800-81800	TOOL SET	1	

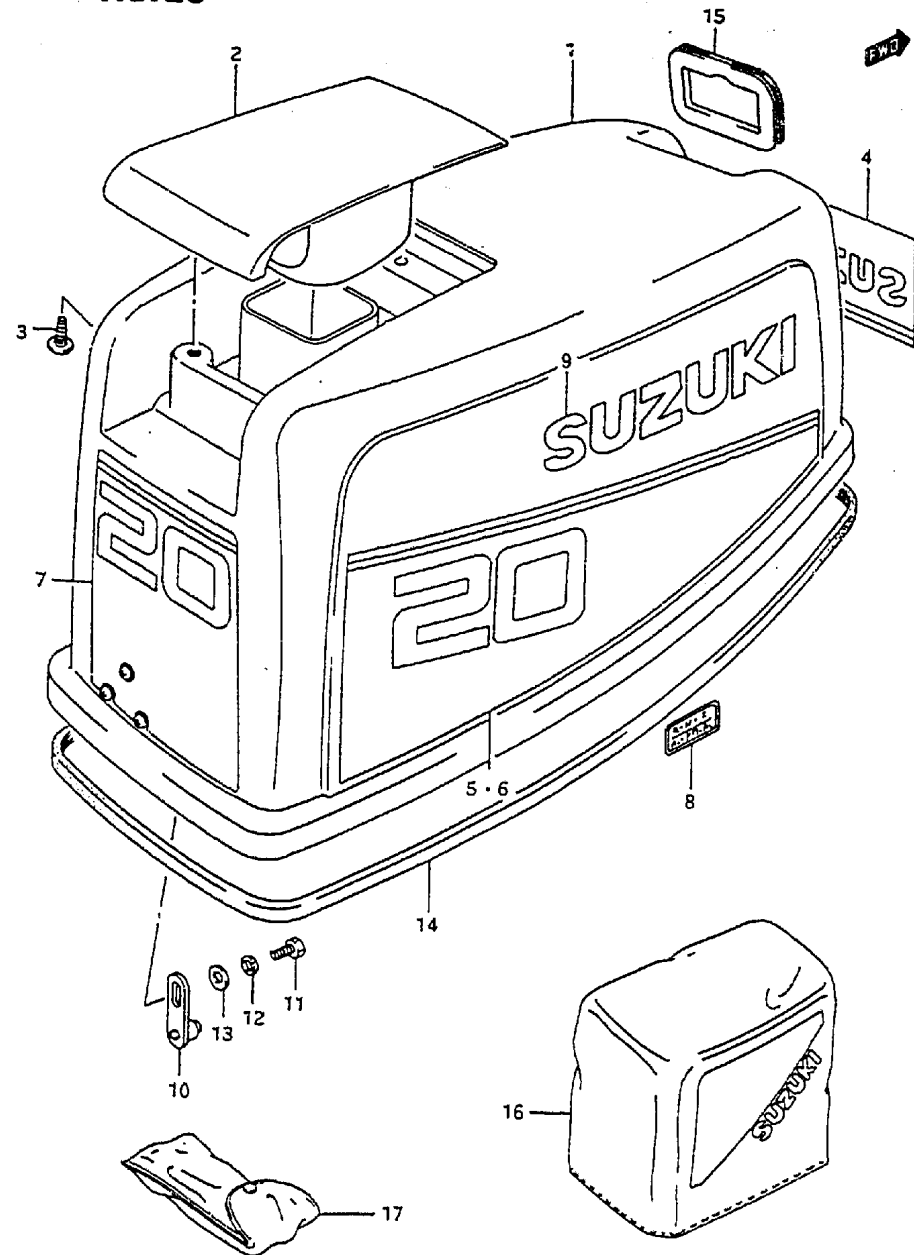
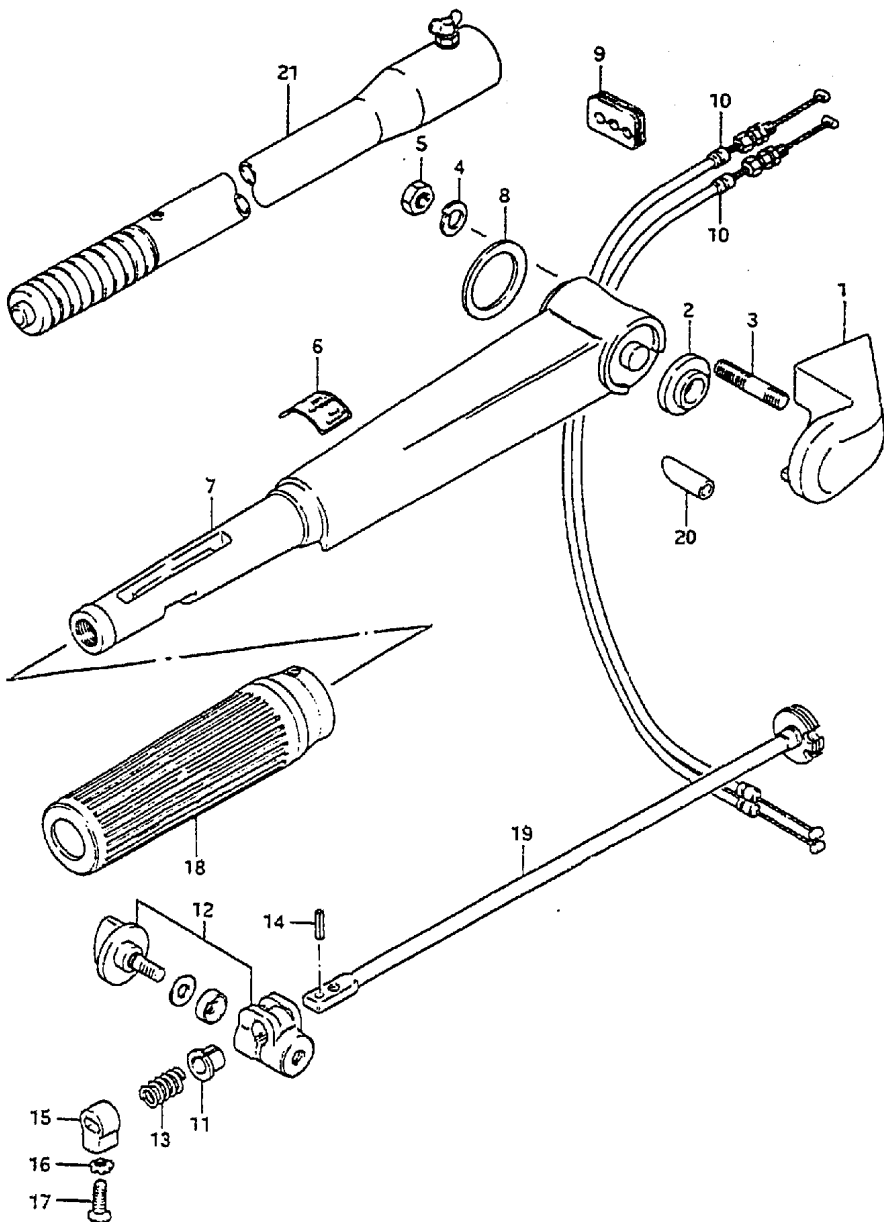

FIG. 24

FIG. 24 ( E- 4) HANDLE

Q'TY

REMARKS



REF.NO.	PART NO.	DESCRIPTION	Q'TY	REMARKS
1	63121-96302-02M	COVER, tiller handle	1	
2	63114-94300	SPACER, handle cover	1	
3	09108-08147	STUD BOLT	2	
4	09162-08007	LOCK WASHER	2	
5	09140-08016	NUT	2	
6	63215-93400	MARK, handle grip	1	
7	63111-96311-02M	HANDLE, tiller	1	
8	63115-96301	SPACER	1	
9	63625-96300	GROMMET	1	
10	63610-96301	CABLE, throttle (L:490)	2	
11	63225-93200	BUSH, handle rod	1	
12	63240-96300	ADJUSTER SET, handle grip	1	
13	09440-12027	SPRING	1	
14	63227-93200	PIN, handle rod	1	L:14
15	63223-93201	STOPPER, handle rod	1	
16	09163-06001	LOCK WASHER	1	
17	09126-06006	SCREW	1	
18	63210-93901	GRIP, handle	1	
19	63220-96300	ROD, handle	1	
20	63117-96300	COVER, stop switch wire	1	
21	63300-93900	BAR ASSY, extension	1	OPT

FIG.25 ( E- 5) FUEL TANK (MODEL VG/VH)

Q'TY

REF.NO.	PART NO.	DESCRIPTION	Q'TY	REMARKS
1	65000-95201	TANK SET, fuel (23L)	1	6 U.S.GAL, 5 IMP.GAL
2	65510-98507	.CAP ASSY	1	
3	65561-98502	..GASKET	1	
4	65871-93010	..GASKET, fuel gauge	1	
5	02112-06162	..SCREW	3	
6	02112-06402	..SCREW	1	
7	09168-06002	..WASHER	4	
8	65850-95506	..GAUGE ASSY, fuel	1	
9	65740-95500	..CONNECTOR, male	1	M12,00:13
10	65854-93001	..GASKET, strainer	1	
11	65853-93001	..STRAINER	1	
12	02112-04102	..SCREW	2	
13	65864-95200	..FLOAT	1	
14	65830-95500	..FILTER, outlet	1	
15	09168-12001	..GASKET (12.5x20x1)	1	
16	65700-95205	HOSE, fuel	1	
17	65750-98505	..CONNECTOR, female	1	
18	65750-93000	..CONNECTOR, female	1	
19	65781-98500	..CLIP	4	
20	65770-99702	..PUMP, squeeze	1	
21	65720-98520	CONNECTOR, male	1	00:11
22	08321-21102	LOCK WASHER	1	
23	08310-22102	NUT	1	
24	65700-95271	HOSE, fuel joint	1	OPT
25	65720-98590	CONNECTOR, male	1	OPT,M12-11

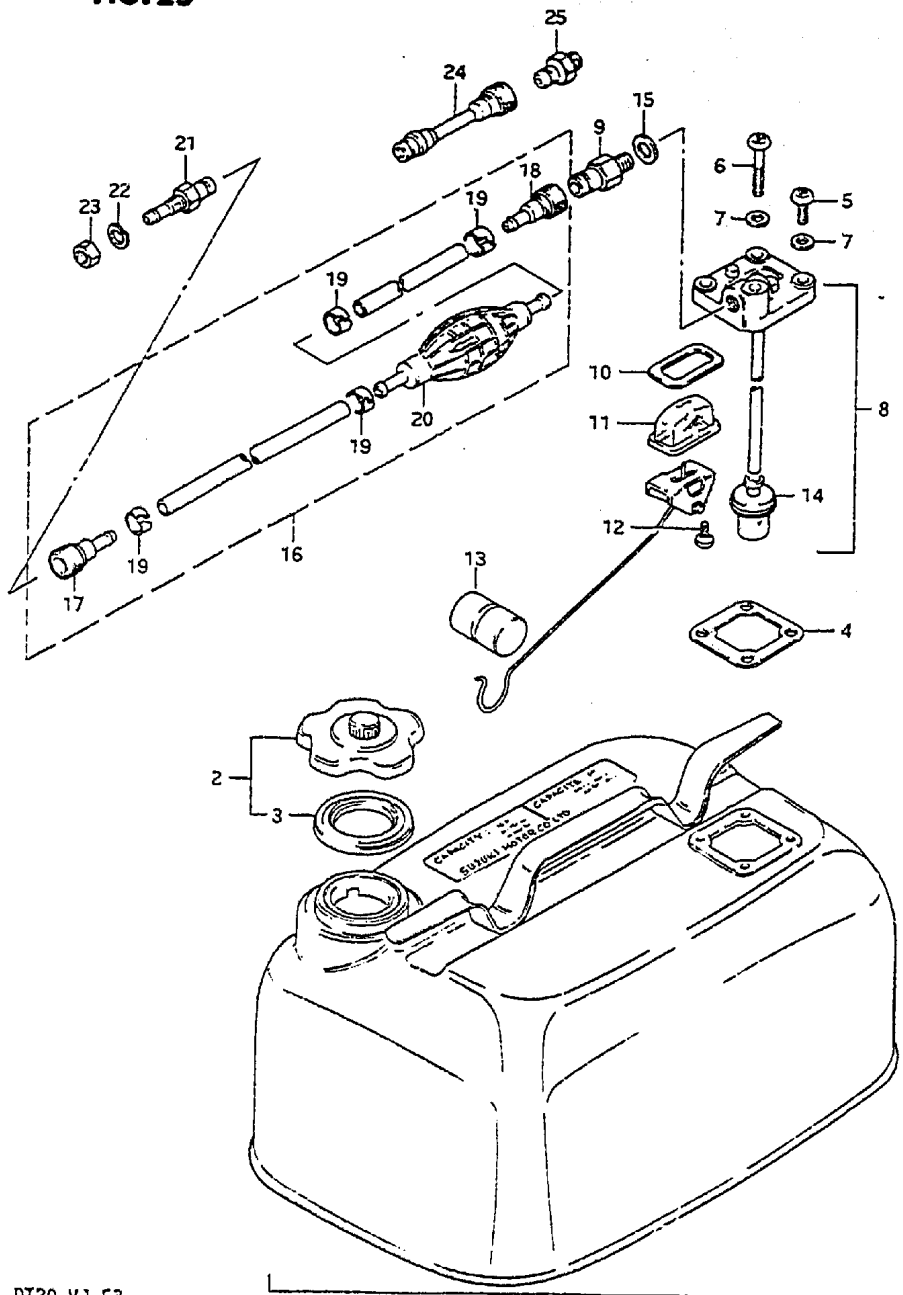
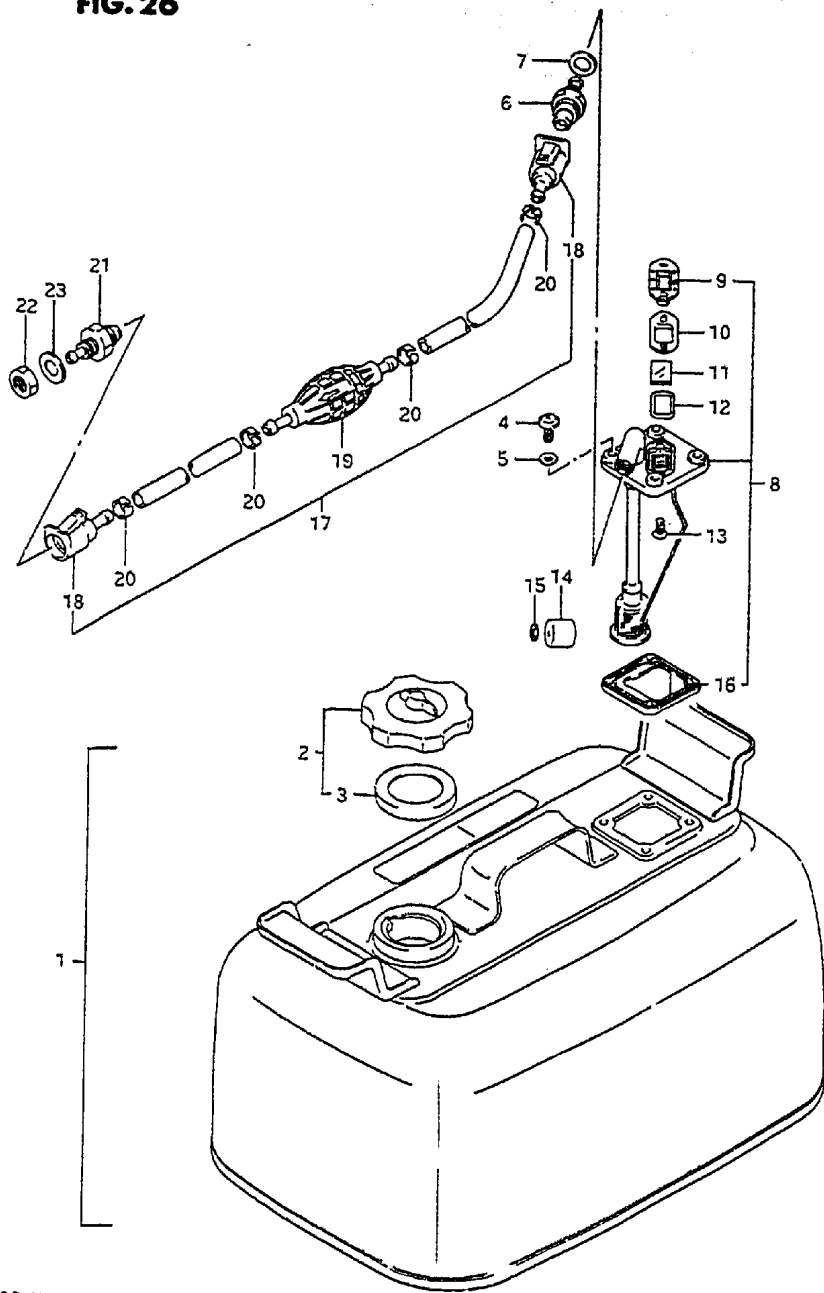



FIG. 26



31

FIG. 26 ( E- 6) FUEL TANK (MODEL VJ)

REF.NO.	PART NO.	DESCRIPTION	Q'TY	REMARKS
1	65800-92820	TANK SET, fuel (24L)	1	6.3 U.S GAL/5.3 IMP GAL
2	65510-92000	.CAP ASSY, separate tank	1	
3	65561-92000	..GASKET, tank cap	1	
4	02152-06162	.SCREW	4	
5	09168-06002	.WASHER	4	
6	65720-94410	.CONNECTOR, fuel	1	
7	09168-12001	.GASKET, connector	1	
8	65850-92000	.GAUGE ASSY, fuel	1	
9	65855-92000	..COVER, gauge	1	
10	65854-92010	..GASKET	1	
11	65853-92000	..LENS	1	
12	65854-92000	..GASKET, lens	1	
13	03221-04086	..SCREW	2	
14	65864-92000	..FLOAT	1	
15	65866-92000	..NUT, push	1	
16	65871-92000	..GASKET, fuel	1	
17	65700-87015	HOSE, fuel	1	
18	65750-94403	.CONNECTOR, fuel	2	
19	65770-95503	.PUMP, squeeze	1	
20	65781-98500	.CLIP	4	
21	65720-94400	CONNECTOR, fuel	1	
22	08310-22102	NUT	1	
23	08321-21102	LOCK WASHER	1	

FIG.27 ( F- 2) OPTIONAL : ELECTRICAL (FOR MANUAL STARTER)

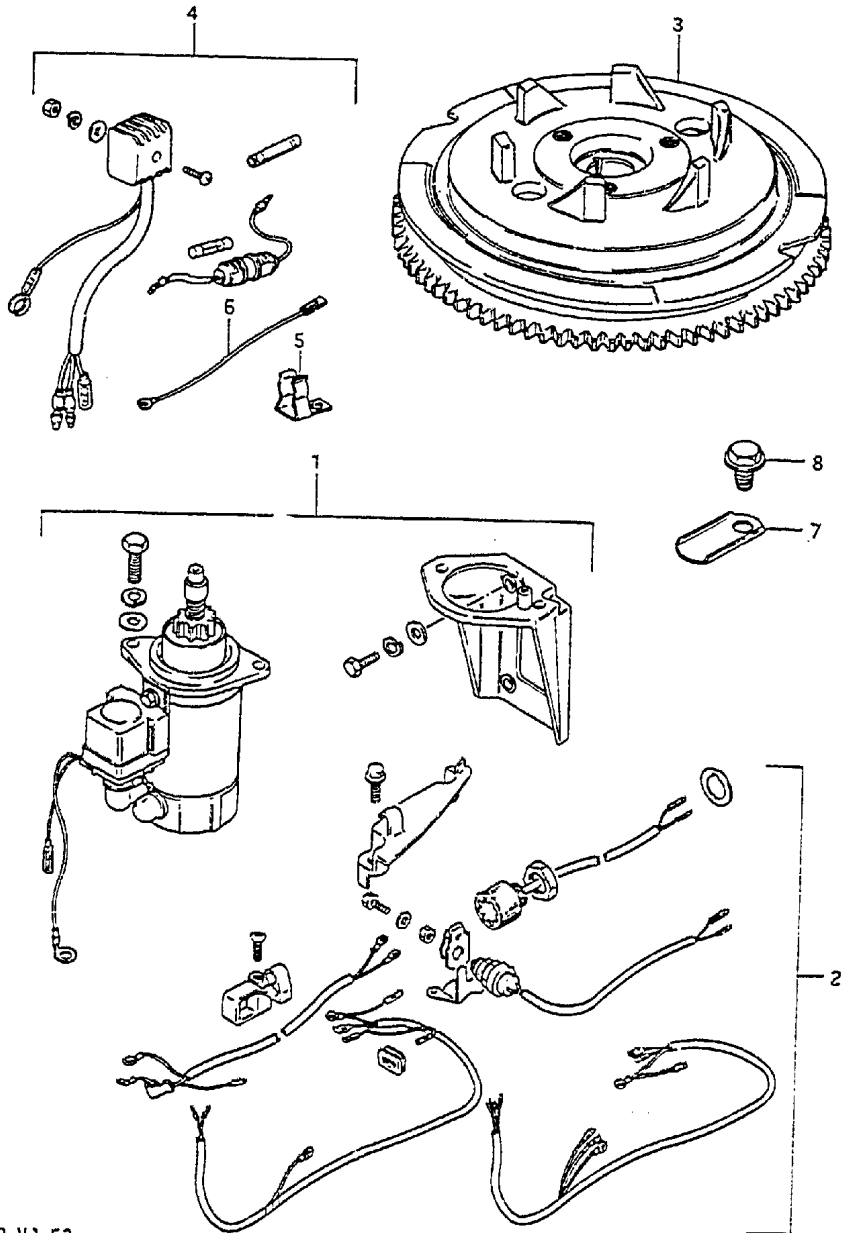

REF.NO.	PART NO.	DESCRIPTION	Q'TY	REMARKS
1	31101-96300	MOTOR SET, starter	1	
2	33800-96301	SWITCH, starter/cable set	1	
3	32102-96380	FLYWHEEL	1	
4	32801-96300	RECTIFIER SET	1	
5	36791-95700	.HOLDER	1	
6	36898-93300	.LEAD, wire	1	
7	33815-94500	PROTECTOR, cable	1	
8	09103-06049	BOLT (6x12)	1	

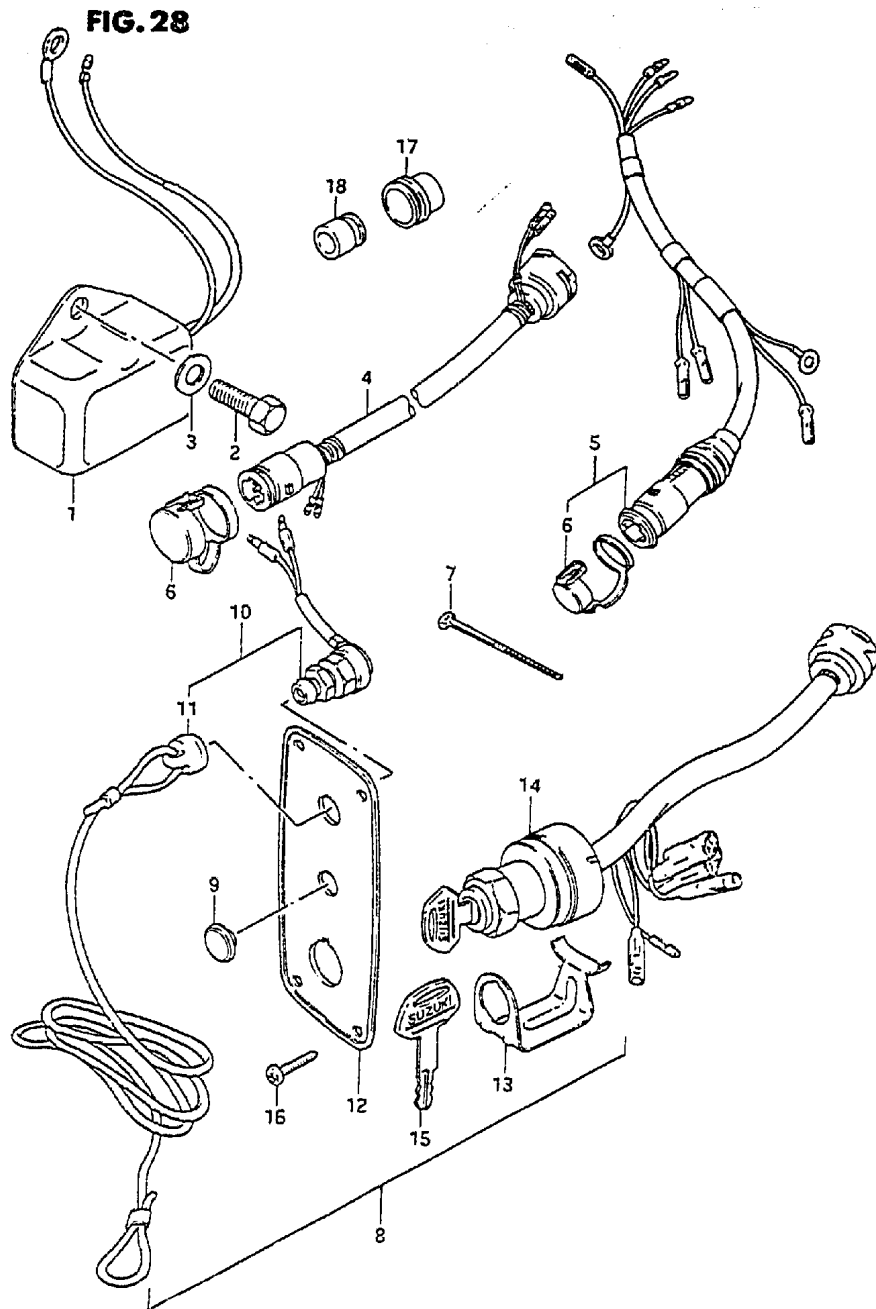
FIG.28 ( F-3) OPTIONAL : ELECTRICAL (FOR ELECTRIC STARTER)  
Q'TY

REF.NO.	PART NO.	DESCRIPTION	Q'TY	REMARKS
1	32500-95722	REGULATOR, voltage	1	
2	01107-06122	BOLT	2	
3	08322-21062	WASHER	2	
4	36620-87D20	WIRING HARNESS, extension	1	
5	36630-96330	WIRING HARNESS, remo-con	1	
6	36631-94300	.CAP, remo-con harness	1	
7	36632-95501	CLAMP, connector grommet	1	
8	37100-95210	PANEL ASSY, switch	1	
9	37101-93310	.CAP, panel	1	
10	37820-95353	.SWITCH ASSY, emargency	1	
11	37823-95251	..CAP	1	
12	37139-95251	.PLATE, switch	1	
13	37150-93350	.HOLDER	1	
14	37110-95210	.SWITCH, ignition	1	
15-1	37141-93300	..KEY, 8511	1	
15-2	37141-93310	..KEY, 8512	1	
15-3	37141-93320	..KEY, 8513	1	
15-4	37141-93330	..KEY, 8611	1	
15-5	37141-93340	..KEY, 8612	1	
15-6	37141-93350	..KEY, 8613	1	
16	03112-04129	SCREW	4	
17	36612-94301	GROMMET, 1	1	
18	36613-94300	GROMMET, 2	1	

**FIG. 29**

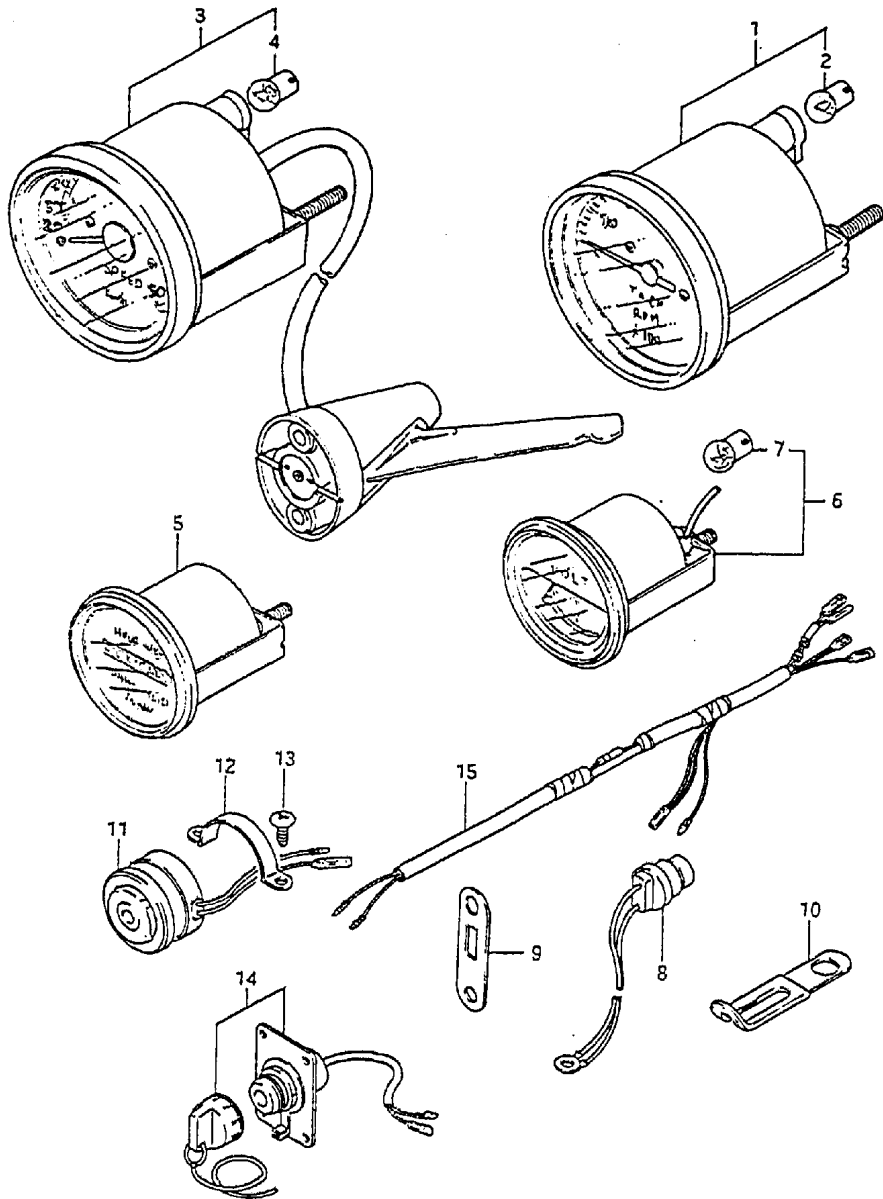

**FIG. 29 ( F- 4 ) OPTIONAL : ELECTRICAL**

REF.NO.	PART NO.	DESCRIPTION	Q'TY	REMARKS
1	34200-95512	TACHOMETER ASSY	1	
2	09471-12001	.BULB (12V,3.4W)	1	
3	34100-95502	SPEEDOMETER ASSY	1	KNOT
4	09471-12001	.BULB (12V,3.4W)	1	
5-1	34500-95502	METER ASSY, hour	1	
5-2	34500-95510	METER ASSY, hour	1	QUARTZ
6	34600-95504	METER ASSY, VOLTAGE	1	
7	09471-12001	.BULB (12V,3.4W)	1	
8	34850-94700	SWITCH, heat	1	
9	34853-94301	SUPPORTER, unit	1	
10	09404-08201	CLAMP (L:52)	1	
11	38500-95503	BUZZER, warning	1	
12	38501-95500	BAND, warning buzzer	1	
13	02112-05088	SCREW	2	
14	34108-94500	SWITCH ASSY, meter	1	
15	34109-94500	LEAD, meter extension	1	

FIG. 30

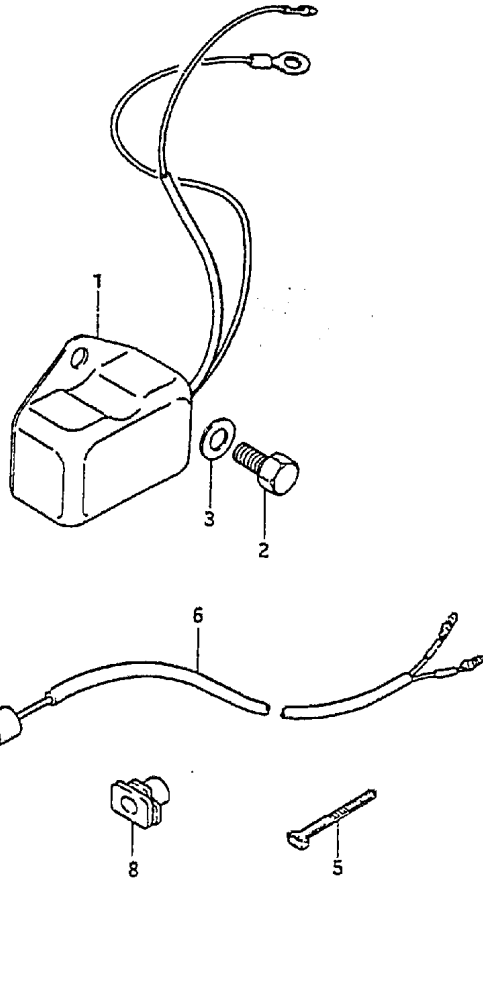

FIG.30 ( F- 5) OPTIONAL : ELECTRICAL (FOR MANUAL STARTER)  
Q'TY

REF.NO.	PART NO.	DESCRIPTION	Q'TY	REMARKS
1	32500-95722	REGULATOR, voltage	1	
2	01107-06122	BOLT	2	
3	08322-21062	WASHER	2	
4	39600-93900	CONSENT SET	1	
5	36632-95501	.CLAMP	1	
6	39601-93902	.CONCENT ASSY, lamp	1	
7	39602-93900	.PLUG ASSY, lamp cord	1	
8	39603-93900	.GROMMET	1	

FIG.31

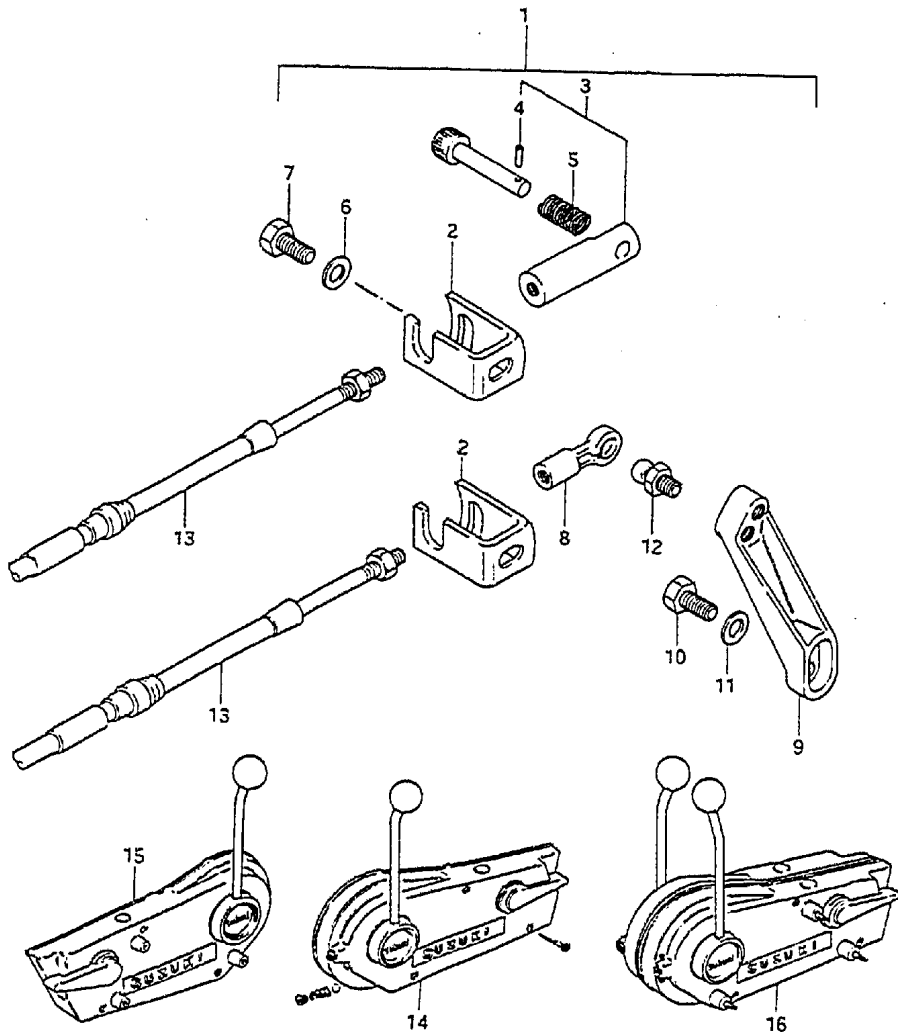

FIG.31 ( F- 6) OPTIONAL : REMOTE CONTROL PARTS

REF.NO.	PART NO.	DESCRIPTION	Q'TY	REMARKS
1	67130-94302-02M	REMOTE CONTROL PARTS ASSY	1	
2	67341-94301	.HOLDER, remo-con cable	2	
3	67440-93701	.GUIDE, clutch cable	1	
4	09205-02006	..SPRING PIN	1	
5	09440-09012	..SPRING	1	
6	09160-06015	.WASHER (6.5x13x1)	2	
7	09100-06115	.BOLT (6x15)	2	
8	67466-95200	.CONNECTOR, remo-con cable	1	
9	67414-94301-02M	.LEVER, remo-con throttle	1	
10	09100-06115	.BOLT (6x15)	1	
11	09160-06015	.WASHER (6.5x13x1)	1	
12	09119-06047	.BALL PIVOT	1	
13-1	67320-95500	CABLE, remocon 6F (1.8M)	2	
13-2	67320-95510	CABLE, remocon 7F (2.1M)	2	
13-3	67320-95520	CABLE, remocon 8F (2.4M)	2	
13-4	67320-95520	CABLE, remocon 9F (2.7M)	2	
13-5	67320-95540	CABLE, remocon 10F (3.1M)	2	
13-6	67320-95550	CABLE, remocon 11F (3.4M)	2	
13-7	67320-95560	CABLE, remocon 12F (3.7M)	2	
13-8	67320-95570	CABLE, remocon 13F (4.0M)	2	
13-9	67320-95580	CABLE, remocon 14F (4.3M)	2	
13-10	67320-95590	CABLE, remocon 15F (4.6M)	2	
13-11	67320-95600	CABLE, remocon 16F (4.9M)	2	
13-12	67320-95610	CABLE, remocon 17F (5.2M)	2	
13-13	67320-95620	CABLE, remocon 18F (5.5M)	2	
13-14	67320-95630	CABLE, remocon 19F (5.8M)	2	
13-15	67320-95640	CABLE, remocon 20F (6.1M)	2	
13-16	67320-95650	CABLE, remocon 22F (6.7M)	2	
14	67200-95203	BOX ASSY, remocon STBD	1	
15	67200-95213	BOX ASSY, remocon PORT	1	
16	67200-95871	BOX ASSY, twin remocon	1	

FIG. 32

37

FIG.32 ( F- 7) OPTIONAL : REMOTE CONTROL

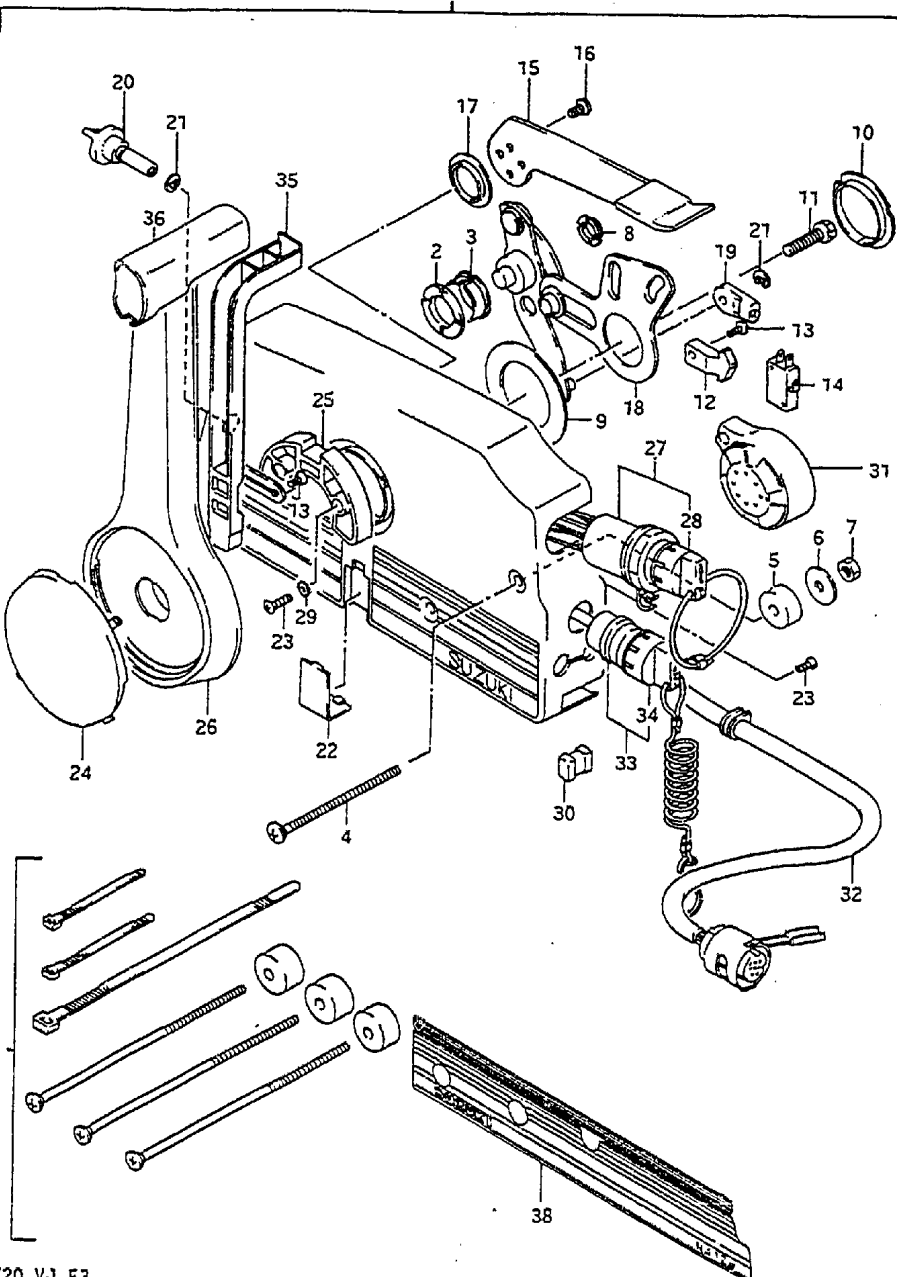

REF.NO.	PART NO.	DESCRIPTION	Q'TY	REMARKS
1-1	67200-94610-02M	REMOTE CONTROL BOX ASSY	1	model VG,VH with ELECTRIC START PARTS
1-2	67200-94630-02M	REMOTE CONTROL BOX ASSY	1	model VJ with ELECTRIC START PARTS
1-3	67200-93960	REMOTE CONTROL BOX ASSY	1	SHIFT AND THROTTLE ONLY
2	67232-95600	.BUSH	1	
3	67232-95600	.BUSH	1	
4	67296-95600	.SCREW	3	
5	67294-95600	.SPACER	3	
6	67288-94310	.WASHER	3	
7	09140-06004	.NUT	3	
8	67232-95610	.BUSH	2	
9	67253-95600	.WASHER	1	
10	67252-95600	.BUSH	2	
11	09100-08232	.BOLT	1	
12	67214-95600	.ACTUATOR	1	INC. 67200-94610-02M, 67200-94630-02M
13-1	67296-94300	.SCREW	3	INC. 67200-94610-02M, 67200-94630-02M
13-2	67296-94300	.SCREW	2	INC. 67200-93960
14	37721-94600	.SWITCH, neutral	1	INC. 67200-94610-02M, 67200-94630-02M
15	67241-95650	.LEVER, free throttle	1	
16	09126-05003	.SCREW	2	
17	67243-95600	.BUSH	1	
18	67220-95600	.PLATE ASSY	1	
19	67275-95600	.END, cable	2	
20	67223-95600	.KNOB, brake ADJ	1	
21	67292-94300	.E RING	3	
22	67267-95610	.COVER, wire	1	
23	67296-95610	.SCREW	7	
24	67257-95610	.CAP, lever	1	
25	67256-95600	.HOLDER, neutral lock	1	
26	67251-95650	.LEVER, handle	1	
27	37110-94601	.IGNITION SWITCH	1	INC. 67200-94610-02M, 67200-94630-02M

FIG. 32

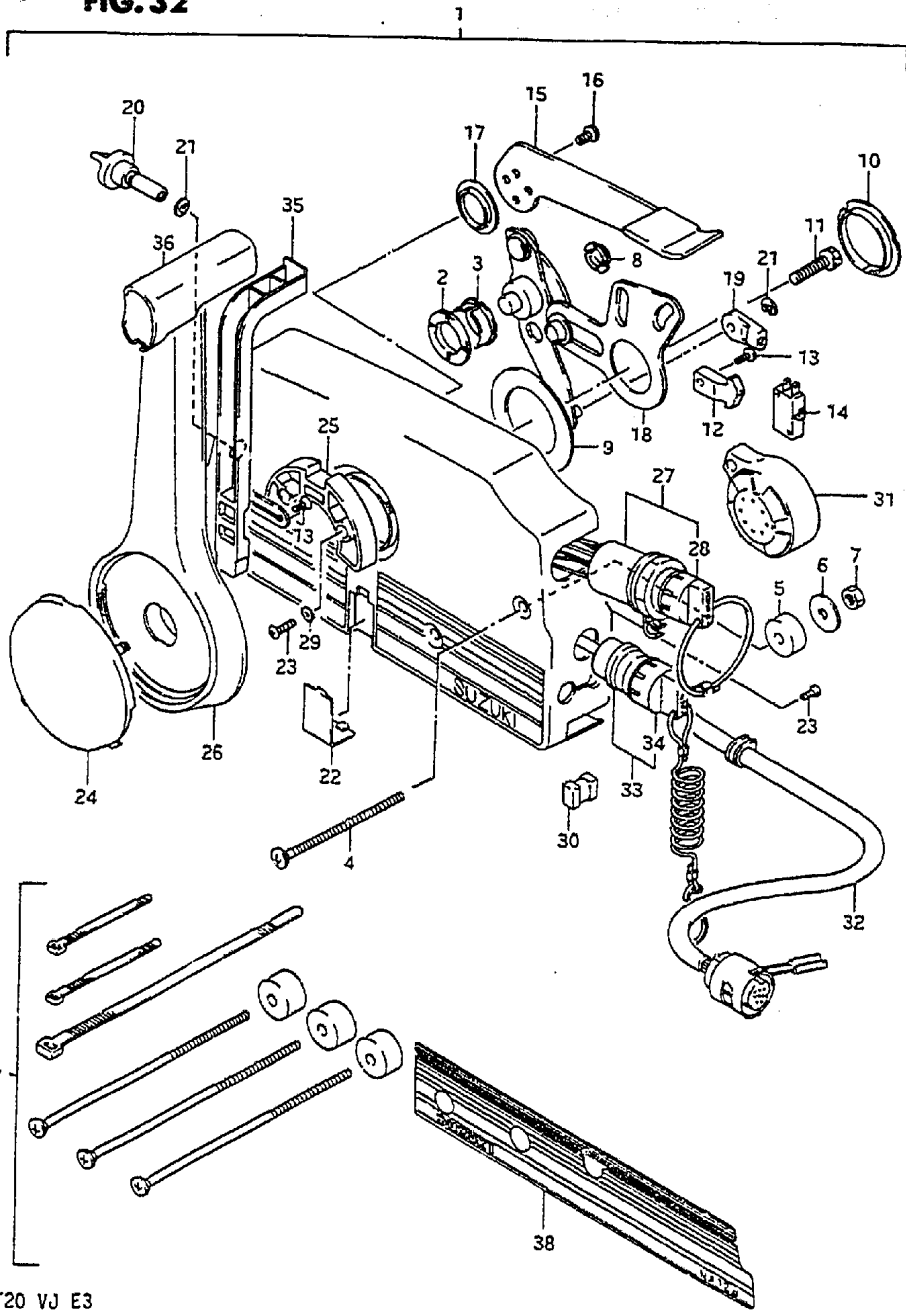

38

FIG.32 ( F- 8) OPTIONAL : REMOTE CONTROL

REF.NO.	PART NO.	DESCRIPTION	Q'TY	REMARKS
28-1	37141-94400	..KEY (101)	1	
28-2	37141-94410	..KEY (102)	1	
28-3	37141-94420	..KEY (103)	1	
28-4	37141-94430	..KEY (104)	1	
28-5	37141-94440	..KEY (105)	1	
28-6	37141-94450	..KEY (106)	1	
29	67297-95600	.WASHER	2	
30	67273-95600	.SPACER	1	
31-1	38500-87000	.BUZZER	1	INC. 67200-94610-02M
31-2	38500-87010	.BUZZER	1	INC. 67200-94630-02M
32	36620-94610	.WIRING HARNESS 7 WIRES	1	INC. 67200-94610-02M, 67200-94630-02M
33	37820-94402	.SWITCH ASSY, emergency	1	
34	37823-94400	..CAP & ROPE	1	
35	67255-95600	.ARM, neutral lock	1	
36	67261-95610	.GRIP	1	
37	67140-95600	ATTACHMENT, twin remo con kit	1	
38	67282-95610	DECAL, remo con box PORT	1	Black



**FIG. 33**

**FIG. 33 ( F- 9) OPTIONAL : DRAG LINK**

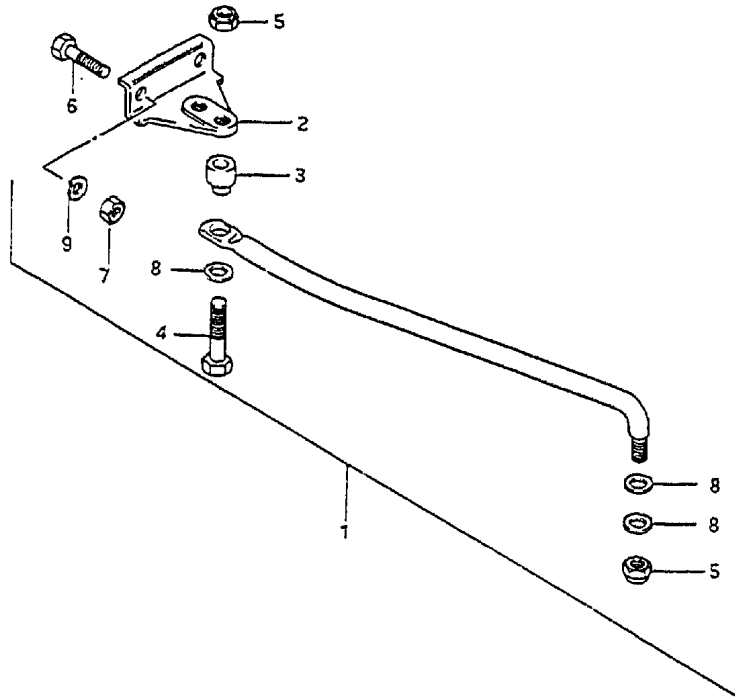

REF.NO.	PART NO.	DESCRIPTION	Q'TY	REMARKS
1	67701-96300	DRAG LINK ASSY	1	
2	43755-96301	.ATTACHMENT, steering BRKT	1	
3	67721-94300	.SPACER	1	
4	67725-94500	.BDLT	1	
5	67726-94500	.NUT	2	
6	09100-08224	.BOLT	2	
7	09140-08016	.NUT	2	
8	67728-94500	.WASHER	3	
9	09162-08007	.LOCK WASHER	2	

FIG. 34

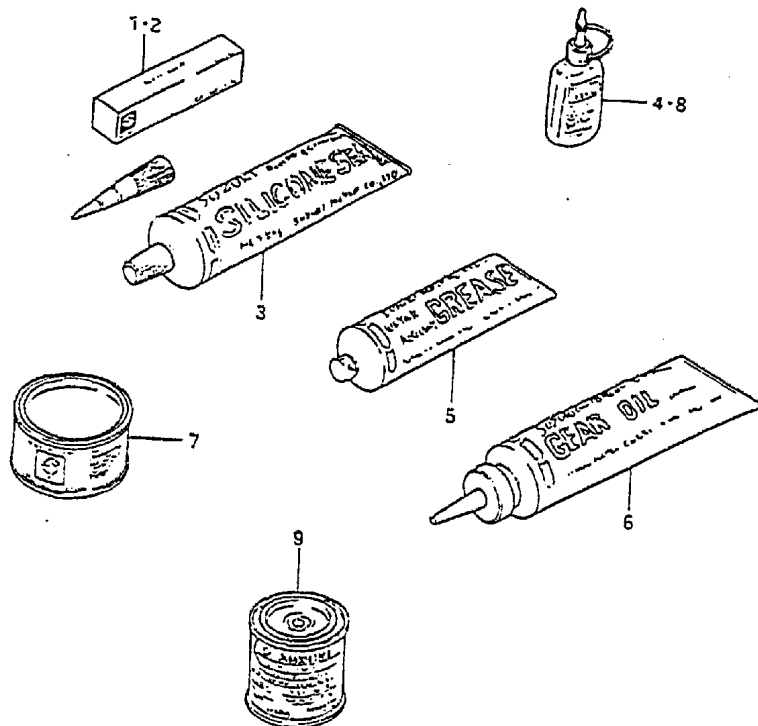

FIG.34 ( F-10) OPTIONAL

REF.NO.	PART NO.	DESCRIPTION	Q'TY	REMARKS
1	99000-31030	GASKET, liquid No.4	1 100g	
2	99000-31050	SUZUKI BOND, No.1	1 100g	
3	99000-31120	SUZUKI SILICON SEAL	1 50g	
4	99000-32050	THREAD LOCK CEMENT, super	1 50g	
5-1	99000-25160	GREASE, water resistant	1 250g	
5-2	99000-25170	GREASE, water resistant	1 50g	
6	99105-50040	GEAR OIL, outboard motor	1 16oz	
7	99000-25010	SUZUKI SUPER GREASE	1 450g	
8	99000-32020	THREAD LOCK CEMENT, super	1 50g,103g	
9-1	99000-10109-01T	PAINT (Francois White)	1 90g	
9-2	99000-10209-02M	PAINT (Arctic Silver)	1 90g	
NOT SHOWN				
	99105-50045	GEAR OIL, outboard motor	1 5 gallon pail	
	99105-00163	PAINT, spray	1 silver	
	99105-00157	PAINT, spray	1 white	

UPDATED DECEMBER 1988